

Embedded Monitoring Method of Greenhouse Environment based on Wireless Sensor Network

Weixue Liu

Chifeng University, Teaching Staff Development Center, Chifeng, 024000, China

Abstract—Aiming at the problem of low accuracy of greenhouse environmental monitoring, an embedded monitoring method of greenhouse environment based on wireless sensor network is studied. The embedded microprocessor S3C2410 is selected as the control chip of greenhouse environmental monitoring. The wireless sensor network is composed of wireless detection node, sink node and remote-control terminal. The temperature and humidity sensor, CO₂ concentration sensor and light intensity sensor are set as the detection nodes of the wireless sensor network. Each detection sensor node is configured with wireless communication module to form a wireless sensor network to realize data communication of environmental monitoring. The distribution map method is selected to eliminate the missing data of greenhouse environmental monitoring data collected by wireless sensor network, and the weighted average method is used to fuse the monitoring data after eliminating the missing data to obtain the final greenhouse environmental monitoring results. The experimental results show that this method can effectively detect the environmental data such as temperature, humidity and light intensity of greenhouse, and the relative error of each data is less than 1%.

Keywords—Control chip; Detection node; embedded; greenhouse environmental monitoring; missing data; wireless sensor networks

I. INTRODUCTION

Facility agriculture is a modern form of agriculture that uses engineering techniques for the efficient production of plants and animals under relatively controlled environmental conditions. Facility agriculture covers facility farming, facility breeding and facility edibles. In addition to this, facility agriculture can improve or create environmental meteorological factors on a local scale to provide good environmental conditions for plant growth and efficient production. Facility agriculture is represented by the intelligent greenhouse, which embodies the direction of modern agriculture. Through greenhouse monitoring methods, various greenhouse environmental factors affecting plant growth can be obtained [1], which plays an important role in improving the yield and efficiency of crops in greenhouses. Among them, how to obtain accurate and reliable greenhouse environmental information is the basis for realising intelligent greenhouses, so information transmission is an indispensable and important link. According to different information transmission methods, greenhouse environmental information can be transmitted via wired communication or wireless communication [2].

Wiring is an unavoidable problem in wired communications. Due to the increasing complexity of the overall structure of modern greenhouses, the use of wired

communication will significantly increase the complexity of design, installation and maintenance. Once a node is damaged, it can lead to the collapse of the entire communication network. Compared to wired communication, wireless communication offers better prospects for application. Infinite communication not only requires no wiring and is easy to maintain at a later stage, but also has the advantage of being able to delete measurement nodes at will [3].

In greenhouse environmental monitoring, the monitoring of various greenhouse environmental factors that affect plant growth is the most critical. The accurate monitoring of various greenhouse environmental parameters can effectively automate and efficiently produce the greenhouse environment [4]. Because facility agriculture gets rid of the constraints of natural climate conditions in traditional agricultural production and overcomes the constraints that traditional agriculture is difficult to solve, it is necessary to monitor greenhouse environmental factors such as temperature, humidity, light intensity and carbon dioxide concentration. China's greenhouse environment has the characteristics of high humidity, high acidity, less infrastructure, many kinds of crops and dynamic changes [5]. Through investigation and analysis, greenhouse monitoring needs mainly include: real-time data acquisition, display and processing of environmental factors such as atmospheric temperature, humidity, light intensity and CO₂ concentration. Traditional sensors are connected by wires, which are very troublesome to wire a large number of wires in greenhouses and are not conducive to agricultural cultivation. Therefore, the application of wireless transmission technology in greenhouses helps to solve the limitations of wired transmission [6]. On the other hand, many agricultural monitoring systems use microcomputers as central controllers, which occupy large space, are costly, and have high environmental requirements [7].

Wireless sensor networks are a research hotspot in the field of information technology in recent years, integrating technologies from many fields, such as sensing technology, computer science, signal and information processing, and communication. The fact that wireless sensors are so obviously interdisciplinary [8] has led researchers formerly working in some specialized fields to start intervening in this field from different perspectives and studying wireless sensor networks from different aspects.

With the development of wireless communication technology, the information transmission method of wireless sensor network began to be applied to the remote monitoring of greenhouse environment. Wireless sensor networks have the characteristics of wide coverage and low influence by the

environment, and can be applied to distributed remote data collection and monitoring. Wireless sensor networks transmit data in the form of short messages, which have the advantages of flexible node deployment and small regional restrictions [9]. As long as there is wireless sensor network signal coverage, nodes can be deployed to collect data. As a new information acquisition and processing technology, wireless sensor network has gradually penetrated into the field of agriculture with its advantages of low power consumption, low cost and high reliability. Greenhouse is a relatively closed environment with limited self-regulation ability. In order to meet the requirements of agricultural production, it is necessary to artificially regulate various environmental parameters of greenhouse in order to create a more suitable environment for crop growth [10]. Monitoring greenhouse environmental information has become a key means to realize the automation and efficiency of greenhouse production. The traditional greenhouse monitoring method is based on wired communication, which has a series of problems, such as complex wiring, difficult maintenance, unable to flexibly deploy sensor nodes and so on, which limits the popularization and application of greenhouse detection methods to a certain extent. With the rapid development of modern information technology, WiFi, Bluetooth, UWB, RFID, ZigBee and other wireless communication technologies have emerged one after another. Among them, WiFi and Bluetooth cannot be popularized and applied on a large scale in the field of greenhouse monitoring due to their high cost and high-power consumption [11].

The history of embedded chips is inevitable, because embedded chips have many advantages. Non-embedded computing chips have good real-time performance, but embedded chip solutions have better advantages in terms of development cost, hardware resources and performance, in line with the development trend. Currently, embedded controllers are used almost everywhere [12]. Mobile devices, represented by cell phones, are the fastest growing embedded industry in recent years. At present, the application of embedded technology has penetrated into various fields such as industry, agriculture, education, national defense, scientific research and daily life. It has played an extremely important role in promoting technological transformation, product upgrading, accelerating the automation process and improving productivity in various industries.

There are many studies on greenhouse environmental monitoring. Pisanu et al. designed a low-cost electronic platform for greenhouse environmental monitoring based on the perspective of agriculture 4.0[13]. This platform can effectively monitor the greenhouse environment, but it has the drawback that the monitoring data cannot be transmitted to the control platform in time; Khan et al. applied the Internet of Things technology to greenhouse plant environment monitoring [14]. The accuracy of greenhouse environment monitoring is low because the sensors set cannot meet the needs of greenhouse environment monitoring.

For the shortcomings of the above two methods, an embedded greenhouse environment monitoring method based on wireless sensor network is studied. As a new information collection and processing technology, ZigBee-based wireless

sensor network has the characteristics of large node size, small size, low cost and ad hoc network. Therefore, it has a broad application prospect in the field of agricultural environment monitoring. This research collects greenhouse environment information through temperature sensors, humidity sensors and other sensors, and transmits the collected information to remote monitoring center through ZigBee wireless sensor network, which is convenient for greenhouse managers to monitor greenhouse environment remotely and in real time and provide a good environment for crop growth.

II. MATERIALS AND METHODS

A. Overall Structure of Embedded Greenhouse Environmental Monitoring based on Wireless Sensor Network

The overall structure of the embedded greenhouse environmental monitoring method based on wireless sensor network is shown in Fig. 1.

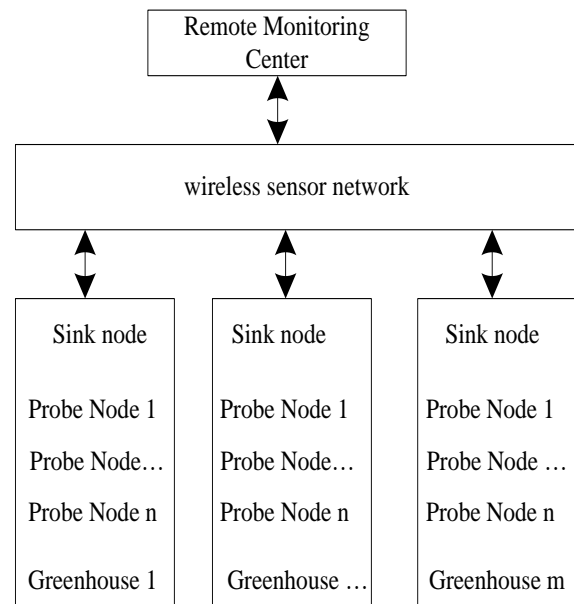

Fig. 1. The overall structure of the embedded greenhouse environmental monitoring method

As can be seen from Fig. 1, the wireless sensor network applied to embedded greenhouse environment monitoring mainly consists of wireless detection nodes, sink nodes and remote control terminals. Each detection sensor node is equipped with a wireless communication module and organized into a wireless sensor network, thus enabling mutual communication and greenhouse environment monitoring. The transmission of information in the network is achieved by "multi-hop" routing, which helps to improve the wireless communication distance and reliability. Each greenhouse has a sink node, which is equipped with a wireless communication module to realize data transmission for remote monitoring of the greenhouse environment network.

B. Wireless Sensor Communication Module

The functional structure of wireless sensor network for monitoring greenhouse environment is shown in Fig. 2.

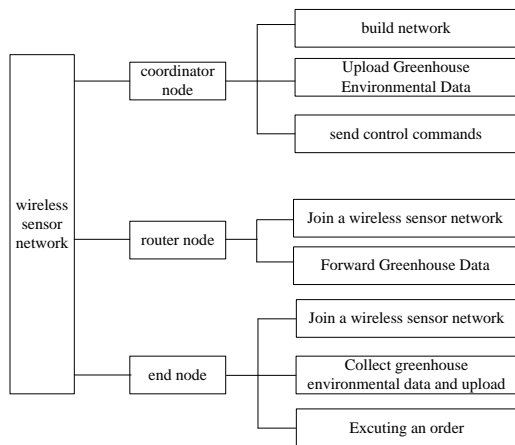

Fig. 2. Functional structure diagram of wireless sensor network

In wireless sensor networks, end nodes are responsible for collecting greenhouse environmental data and sending it to routing nodes. The routing node aggregates the data and sends it to the coordinator node, which then sends the data to the server using the router node [15]. The coordinator node receives action instructions from the server and transmits them to the routing node, which then sends the data in the form of broadcasts to the corresponding terminals for control operations. Throughout the network communication process, each node determines whether the command executor is the node based on its own 16-bit short address. If it is the node, it performs the corresponding execution action; otherwise, it ignores the command.

1) *Communication chip*: The CC2530 chip from TI was selected as the wireless communication module. 8051 CPU used in the CC2530 chip is a single-cycle 8051-compatible core that integrates 8KB of SRAM, Flash memory and an XREG/SFR register. The CC2530-F256 chip of the CC2530 series is selected as the communication chip for greenhouse environment monitoring. The CC2530 chip is very suitable for ultra-low-power greenhouse environment monitoring. The circuit composition of the CC2530 chip includes clock circuit and reset circuit. The clock circuit frequency of the CC2530 chip is composed of two borderless when the communication module is operating normally, the function of Y1 (33.549 KHz) crystal oscillator is to provide low-power mode for the node; the function of Y2 (33MHz) crystal oscillator is to provide clock for the node; the reset circuit is composed of resistor and on/off key. When the on/off key is pressed, the wireless sensor network will return to the initial state. The RF part of the CC2530 chip is responsible for transmitting and loading RF signals. The enhanced 8051 CPU core integrated in the chip is responsible for controlling the RF, peripherals and running the ZigBee protocol stack.

2) *Building zigbee wireless sensor networks*: When building a ZigBee wireless sensor network, the coordinator needs to be powered on while the communication module initializes the protocol stack and hardware. The coordinator sends a BEACON frame from the first channel. If BEACON

responds, it can be concluded that there is another coordinator on this channel. If this occurs, it indicates that the channel is occupied and the coordinator sends BEACON frames to the next channel. This is repeated until no corresponding event for a BEACON frame occurs in a channel. After an empty channel is found, a wireless sensor network can be established. Once the network is established, the coordinator can connect to the device and then the coordinator assigns the network address. The coordinator can then read the data information and then send the transmitted or collected data information to the main control computer. When the coordinator receives an ASSOCIATION_REQ network access request from a ZigBee device, it will send the BEACON signal in response to the node's request [16] and then send the request signal ADDRESS_REQ; if the coordinator receives it, it will send the ADDRESS_ASSIGN signal and wait for an acknowledgement; if the coordinator receives ADDRESS_ASSIGN, the address list will be updated automatically. After power-up, the node will scan the channel to find an available coordinator in the network. After monitoring the beacon signal, the node will send the address assignment request signal ADDRESS_REQ, and then the node will search for the ADDRESS_ASSIGN signal. If it does not find one, it will continue to send the ADDRESS_REQ signal until it receives the ADDRESS_ASSIGN signal. After receiving the signal, the node will send ADDRESS_AK to the coordinator to confirm the signal address.

3) *CSMA / CA protocol and network interception strategy*: Since the commonly used CSMA / CD protocol may be difficult for the adapter to detect whether there is channel conflict for wireless products, this wireless sensor network adopts a new protocol, Carrier Sense Multiple Access with Collision Avoidance (CSMA / CA). CSMA /CA protocol solves the conflict problem caused by multiple wireless devices transmitting data at the same time, and brings convenience to the construction of ZigBee wireless sensor network. CSMA / CA protocol needs to complete the following two tasks: the first is to find the idle channel (carrier listening); the second is to wait for random time (avoiding collision).

a) *IEEE802. 15.4 CSMA / CA classification*: In IEEE802 15.4 in the protocol, there are two ways of multiple access / collision avoidance mechanism for carrier frame: CSMA / CA with time slot and CSMA / CA without time slot. Generally speaking, CSMA / CA with time slot is used for beacon trigger mode, and CSMA / CA without time slot is used for beacon trigger mode. The two algorithms used in CSMA /CA are based on backoff, and the time unit is the backoff period.

b) *CSMA / CA without beacon*: The operation modes of the two protocols of IEEE802. 15.4 are similar, but the backoff time is different. In the network, if there is no super-frame structure, there will be no beacon (time slot) and no network coordinator for signal use. The sensor needs to wait for random time to listen to the activity of the channel. If the channel is

idle, it can send information. Otherwise, the device needs to wait for random time again.

c) *CSMA / CA with beacon*: CSMA / CA with beacon limits the space occupied by the backoff cycle boundary, and the backoff cycle boundary must be at the super-frame cycle boundary, so as to ensure normal operation.

d) *IEEE802. 15.4 CSMA / CA process*: CSMA / CA protocol is mainly used for data transmission of ZigBee devices to avoid mutual interference of signals sent by different ZigBee devices. When the ZigBee device transmits data, it needs to find an idle channel, and it will send a signal for channel competition. If an idle channel is found, the ZigBee device will send a backoff delay time, which is used to prevent other ZigBee devices from occupying this channel at the moment and avoid interference caused by the collision of signals sent by the two devices. However, if the channel found by ZigBee device is busy, the device needs to listen to the channel again and repeat the above process until it finds a free channel.

C. Embedded Control Chip

S3C2410, a 32-bit RISC embedded microprocessor based on ARM920T core, is selected as the embedded chip of greenhouse environmental monitoring. The ARM920T core consists of ARM9TDMI, memory management unit (MMU) and cache. The core board integrates Samsung's S3C2410 processor (32-bit ARM920T core), 16M FLASH and 64M SDRAM, JTAG2ICE debugging interface, etc. The resources of the core board include: 2 UARTS, 1 USB port, data cable and LCD interface. The backplane includes: power circuit, various interface circuits, touch screen, keypad, USB storage circuit, etc. The structure diagram of embedded control chip is shown in Fig. 3.

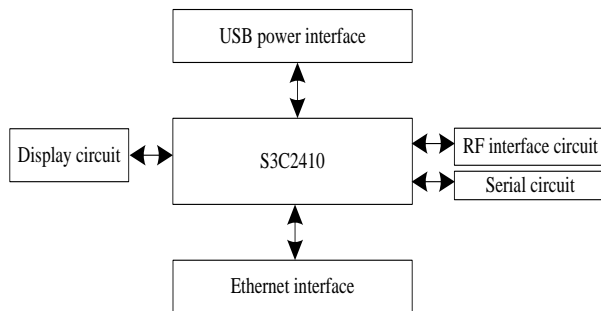

Fig. 3. Embedded control chip hardware structure

The power supply circuit provides the required power supply for each part of the greenhouse monitoring controller [17], and the selected chips are LT1764 and MIC29302. Among them, LT1764 is divided into adjustable and non-adjustable, providing 3.3V and 5.0V voltage respectively; MIC29302 provides a voltage of 4.2V. The voltage of 5.0V is mainly used for LCD circuit and USB circuit, the voltage of 4.2V is used for GPRS circuit, and the other circuits use the voltage of 3.3V. The power supply of the core board is 3.3V, which also comes from the backplane, while the S3C2410 core voltage and I / O voltage require 1.8V and 3.3V respectively. Therefore, AIC1117A is used on the core board to reduce the

3.3V voltage provided by the backplane to 1.8V and provide it to the processor core.

The function of serial interface is to act as an encoder converter between CPU and serial equipment. There are three kinds of asynchronous serial receiving devices provided by the S3C2410 general-purpose serial port and the asynchronous serial port. Each serial port contains a baud rate generator, a transmitter, a receiver and a control unit. The greenhouse controller uses the two serial port resources provided by the core board. According to the design requirements, the two serial ports are set as the standard RS2232 serial port. In addition to the function of ordinary serial port, serial port 1 also undertakes the task of wireless sensor network communication and acts as the debugging terminal of embedded control chip. Since the core board provides TTL level, MAX3232 chip is used to convert the voltage into a voltage conforming to RS2232 standard.

D. Greenhouse Environmental Monitoring Sensor

As a monitoring device to help people understand the external environment, sensors can detect and perceive the surrounding environmental information, and express various abstract environmental factors in the environment in the form of electrical signals according to certain rules. At the same time, as a machine, there is no subjective feeling, and the perception of the external environment can be expressed more accurately. Therefore, sensors are widely used in current industrial production. In the process of sensor selection, many factors need to be considered, including measurement range, working temperature, measurement accuracy, cost and matching degree with the chip. At the same time, combined with the particularity of greenhouse environment, the appropriate device can be selected. The corresponding sensor is selected according to the environmental parameters to be collected for greenhouse environmental monitoring, and the sensor is selected considering the cost, sensor accuracy and matching degree with the main control module.

1) *Temperature and humidity sensor*: Among AM2302 air temperature and humidity sensor is selected as the sensor for temperature and humidity collection in greenhouse environmental monitoring. It is characterized by not only capacitive humidity sensing elements, but also high-precision temperature sensing elements. Each element is calibrated with specific temperature and humidity, and can be used only after passing the inspection. AM2302 air temperature and humidity sensor has an 8-bit single chip microcomputer, so the response speed is relatively fast and the anti-interference is also very good. Because of its small size, it has low energy consumption. In addition, it has a series of advantages of single bus interface, so it can be widely used in meteorological stations and other places where temperature and humidity monitoring is needed. Due to the integrated packaging, the signal strength and anti-interference ability of the air temperature and humidity sensor are greatly enhanced [18]. The chip provides a two-wire serial interface similar to I2C bus, which is connected with the input interface of the host through bidirectional serial data line data and serial clock input SCK.

It not only inherits the characteristics of simple use of I2C interface, but also supports CRC verification of data transmission results to ensure the reliability of data transmission.

The air temperature and humidity sensor use single bus to communicate with MCU, and only one I / O port is needed to realize data transmission. The temperature and humidity data inside the sensor is transmitted to the single chip microcomputer at one time through the pin. The data is composed of 40bit, and the data is divided into decimal part and integer part. The transmission format is: 8bit humidity integer data + 8bit humidity decimal data + 8bit temperature integer data + 8bit temperature decimal data + 8bit verification data. The check data is the last eight bits of the sum of the first four bytes. The data output by the air temperature and humidity sensor is eight-bit binary data, which represents the real temperature and humidity.

When the bus is idle, it is high level. When the embedded control chip sends the start signal to AM2302, it pulls down the bus for at least 18ms to ensure that the AM2302 chip can detect the start signal. After detecting the start signal, AM2302 will convert from low-speed mode to high-speed mode. Then, the bus will be pulled up by the pull-up resistance for 20-40us, to read the response signal of AM2302, wait for it to pull down the data line and keep it for 80us, and then pull it up for 80us, finally start data transmission. The data of each bit starts with a 50us low-level slot. Whether the data bit is "0" or "1" is determined by the length of the high-level. If the high-level is 26-28us, the data "0" is sent, and if the high-level is 70us, the data "1" is sent. After all data is transmitted, AM2302 pulls down the bus by 50us, and then pulls up the bus through the pull-up resistor to enter the idle state.

2) *CO₂ Concentration Sensor*: MH-Z14CO₂ concentration sensor is used as the concentration acquisition sensor for greenhouse environmental monitoring. MH-Z14CO₂ concentration sensor integrates the A / D conversion module and comparator. The conductivity of the module can be enhanced with the increase of gas concentration. The A / D conversion circuit in the module can convert this change into voltage change. The single chip microcomputer can directly read the voltage value or digital switching value. The module directly converts the gas concentration into the corresponding voltage value. The single chip microcomputer collects and reads the voltage through A / D, and then obtains the gas concentration value in proportion. The detected concentration is 100-10000ppm. MH-Z14 sensor has a long service life, which reduces the cost to a certain extent. At the same time, it also has the performance of temperature compensation to ensure the measurement accuracy. Based on the above advantages, MH-Z14 sensor is widely used in the production environmental monitoring of industrial and agricultural equipment.

3) *Light intensity sensor*: The regulation of light in the greenhouse environment is mainly to increase the light intensity in the warm room. The demand for light intensity varies greatly among different crops. Generally, when the light intensity in the warm room decreases to 1000 lux, the crops in

the warm room should be supplemented with light. According to the requirements of greenhouse crops for light intensity [19], the illuminance sensor BH1750fvi produced by Rohm company is selected. The high resolution of BH1750 can detect a wide range of light intensity changes (1lx-65535lx), and the visible light in 400nm-700nm band has excellent sensitivity. Logic+I2C Interface is the interface between light intensity calculation and I2C bus. PD is a photodiode, and its sensitivity is similar to that of human eyes; AMP integrated operational amplifier can convert PD current into PD voltage; ADC analog-to-digital conversion obtains 16-bit digital data. The ADDR port of register accumulator of BHT1750 illuminance sensor is grounded, and the two serial ports of clock end SCL and data end SDA are connected with CC2530. The working principle of the light intensity sensor is to convert the light intensity value into voltage value. Firstly, it initializes the program, then configures the input mode, collects data and carries out A / D conversion. After the conversion, the single chip microcomputer reads the conversion directly.

E. Sensor Data Fusion Method

The temperature in the greenhouse is described by multiple measurement points. The temperature in the greenhouse changes with space. At the same time, the temperatures measured in different places in the greenhouse are also different. In order to control the temperature, humidity and other factors in the greenhouse, we must give an equivalent value to describe the temperature, humidity and other states of the current greenhouse consistently. Therefore, we use data fusion method to determine the effective value, which is used to control the greenhouse, such as rolling shutter, heating equipment, ventilation equipment, etc. Data fusion makes full use of multiple sensor resources. Through the reasonable control and use of these sensors and their observation information, the redundant or complementary information of multiple sensors in space or time is combined according to some criteria, so as to obtain better performance than the subset of its components.

After using wireless sensor network to collect greenhouse environmental monitoring data, we should first eliminate the missing data. There are many methods to eliminate the missing data, and select the distribution map method to eliminate the missing data.

The main parameters used in the distribution map are: median X_M , upper quartile F_u , lower quartile F_l , quartile dispersion dF and elimination point ρ . Their definitions and usage are as follows:

Firstly, it can carry out multiple independent measurements on a tested object, and arrange the measured data in the order from small to large:

X_1, X_2, \dots, X_N , then X_1 is called the lower limit and X_N is called the upper limit.

Secondly, the median value X_M is defined:

$$X_M = \frac{(N+1)X}{2} \quad (1)$$

$$X_M = \frac{\left(\frac{N+1}{2} + \frac{N}{2}\right)X}{2} \quad (2)$$

Thirdly, in the partition map method, if the median of interval $[X_M, X_N]$ is F_u , F_u is the upper quartile, and the lower quartile F_l is the median of interval $[X_1, X_M]$

Fourthly, the dispersion dF of the quartile is defined as:

$$dF = F_u - F_l \quad (3)$$

It is stipulated that the data whose distance from the median is greater than βdF is divorce data, that is, the judgment interval of invalid data is:

$$X_i - XM > \beta dF \quad (4)$$

Where, β is a constant, and its size is determined according to the accuracy requirements of greenhouse monitoring. The elimination point is defined as:

$$\rho_1 = \frac{(F_l - \beta) dF}{2} \quad (5)$$

$$\rho_2 = \frac{(F_u - \beta) dF}{2} \quad (6)$$

The measurement data outside the interval $[\rho_1, \rho_2]$ is considered as the elimination point.

After the above steps, the remaining data are consistency measurement data. We can fit the consistency data. The weighted average method is selected to fuse the data collected by the sensor. Since many sensors are placed in the greenhouse, the greenhouse data collected by each sensor is different [20], so it is necessary to fuse the data collected by wireless sensors to give users an effective value to guide users to operate the greenhouse. The problem is described as follows: there are n temperature wireless sensors in the greenhouse, and the greenhouse data collected by each wireless sensor at t time is t_1, t_2, \dots, t_n . Firstly, the distribution diagram method is used to eliminate the missing data, and the data are sorted to obtain the consistent data columns t_e, \dots, t_p . Weight is represented by w_i . w_i is usually selected as

$\frac{1}{p-e}$, and the average value of the temperature in the greenhouse is calculated by the weighted average method:

$$\bar{T} = \sum_{i=e}^p \frac{t_i}{p-e} \quad (7)$$

The weighted average method is simple, easy to implement and occupies less resources. When the wireless sensor network is used to monitor the embedded greenhouse environment, the weighted average method is used to fuse the data collected by the sensor to obtain the final greenhouse monitoring parameters such as ambient temperature and ambient humidity.

III. RESULTS

In order to verify the effectiveness of the embedded environmental monitoring method of greenhouse based on wireless sensor network, the method in this paper is applied to the greenhouse environmental monitoring of an agricultural production. The average communication distance between the deployed nodes of the wireless sensor network is about 20m, and the nearest distance between the monitoring node and the gateway node is about 100m. After installation and operation, after the gateway is started, the average time required for node binding and ad hoc network establishment is less than 1min. The sampling frequency setting scheme of sensor nodes is: air temperature and humidity for 2min, soil temperature and humidity for 10min, light intensity for 3min and CO2 concentration for 30min. After completing data collection and transmission, each node will automatically enter the sleep state until the next sampling cycle wakes up.

In order to verify whether the communication stability between nodes of wireless sensor network is good and whether the communication quality is qualified, the packet loss rate of wireless sensor network is tested. Packet loss rate refers to the proportion of data packets not received in a certain period of time in the total data packets sent. If the packet loss rate is too high, it indicates that a large number of temperature and humidity, smoke concentration and light intensity data have not been collected, which will lead to the control node cannot accurately turn on and off the relevant equipment, cannot accurately monitor the environment in the shed, resulting in measurement failure. To ensure the reasonable distance between network nodes, it needs to try to ensure a low packet loss rate and enhance the accuracy of measurement. The greenhouse in the study area is selected as the test site. The coordinator is placed in the monitoring room, adjacent to the upper computer, and the terminal equipment is placed in different positions in the greenhouse. The transmit power of CC2530 processor is -3dBm; the total number of single packet test is set to 2000, and the packet sending speed is one group per second, with 5 packets per group. This speed fully meets the needs of the actual project. After fixing the coordinator position, it can send the same number of data packets at the terminal nodes in different positions of the greenhouse, to measure the number of received data packets, and calculate the packet loss rate. The calculation of packet loss rate is shown in the following formula:

$$A = \frac{B - C}{B} \times 100\% \quad (8)$$

In formula (8), *B* and *C* represent the transmitted data packet and received data packet of wireless sensor network respectively.

Using the method in this paper to collect greenhouse environment data, the communication performance of wireless sensor network is shown in Table I.

TABLE I. WIRELESS SENSOR NETWORK COMMUNICATION PERFORMANCE

Sensor terminal serial number	Distance from gateway node	number of packets sent	Number of received packets
1	5	2000	1999
2	10	2000	1999
3	15	2000	1999
4	20	2000	1997
5	25	2000	1995
6	30	2000	1991
7	35	2000	1987
8	40	2000	1985
9	45	2000	1981
10	50	2000	1976
11	55	2000	1961
12	60	2000	1958

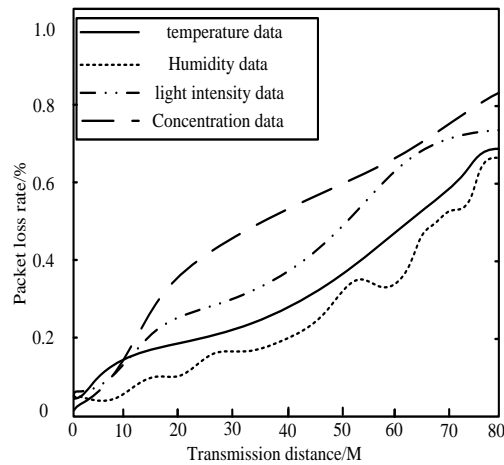

Fig. 4. Statistics of packet loss rate

The data of greenhouse environment monitored by wireless sensor network used in this paper are statistically analyzed and the packet loss rate results of collecting different types of greenhouse environmental data are shown in Fig. 4.

According to the experimental results in Fig. 4, the wireless sensor network is greatly affected by the transmission distance. Within the short range of 10 meters, the data packet loss rate maintains a low value within 0.1%. However, when the

distance between the sensor terminal and the coordinator is more than 10 meters, the packet loss rate increases sharply, which is caused by the great irregularity of the communication link of the low-power module. Through the experimental test, even when the packet loss rate of 80m is the largest, the packet loss rate of ZigBee wireless communication is still less than 1%, which meets the needs of greenhouse environmental monitoring.

In the greenhouse monitoring area, each monitoring point is equipped with three sensors. The method in this paper is used to fuse the greenhouse environmental data collected by the three sensors to improve the accuracy of greenhouse environmental data collection. The temperature data of different monitoring points in the greenhouse are collected by this method, and the results are shown in Fig. 5.

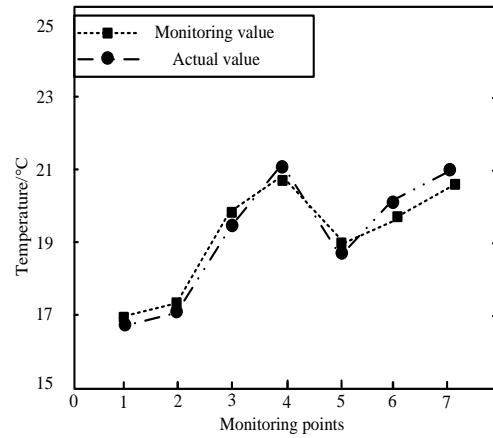

Fig. 5. Temperature data collection results

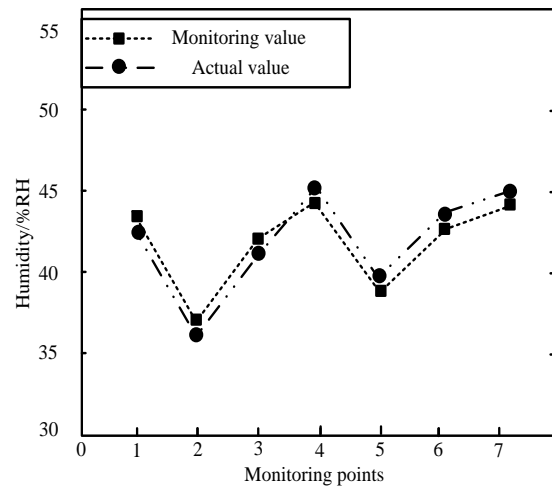

Fig. 6. Collection results of ambient humidity

The humidity data of different monitoring points in the greenhouse are collected by the method in this paper, and the results are shown in Fig. 6.

The experimental results in Fig. 5 and Fig. 6 show that the method of this paper is used to monitor the greenhouse environment, and the collected temperature and humidity data of the greenhouse environment is close to the actual

environmental temperature and humidity data of the greenhouse within a reasonable range of error, which indicates that the data collected by the temperature and humidity sensor is accurate and reliable, and the sensor used in this method can effectively monitor the temperature and humidity data of the greenhouse environment. The error is within a reasonable range, which indicates that the data collected by the temperature and humidity sensor is accurate and reliable.

During the experiment, a full spectrum LED lamp is set in the greenhouse to gradually shorten the distance between the full spectrum LED lamp and the lighting intensity measuring equipment, and increase the lighting intensity. The average value of five groups of data is taken for each measurement and compared with the data measured by the digital illuminance meter. The comparison of light intensity data is shown in Fig. 7.

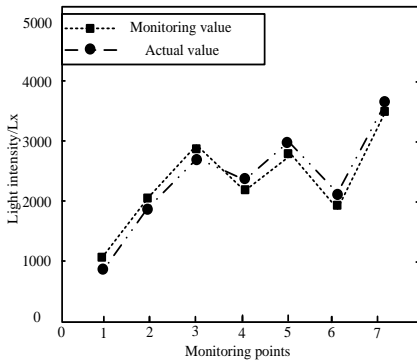

Fig. 7. Comparison of light intensity data

According to the experimental results in Fig. 7, the difference between the greenhouse light intensity data monitored by the method in this paper and the actual light intensity data of greenhouse is small. From the above data, the designed light intensity acquisition circuit is very close to the actual light intensity value, and the error is within a reasonable range. The data collected by the light sensor is accurate and reliable.

The CO₂ concentration data collected at different monitoring points by the method in this paper are counted, and the collected CO₂ concentration data are compared with the actual CO₂ concentration data. The comparison results are shown in Fig. 8.

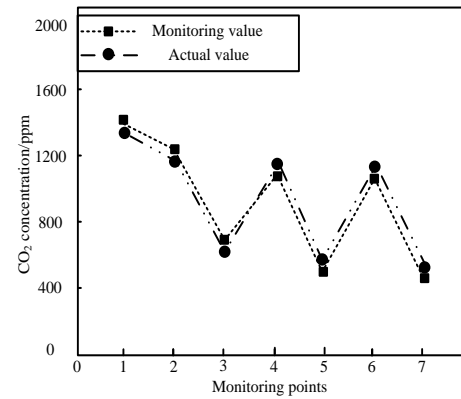

Fig. 8. Comparison of CO₂ concentration data

The experimental results in Fig. 8 verify that the method in this paper can effectively collect CO₂ concentration data, and the collected CO₂ concentration data is very close to the actual CO₂ concentration data of greenhouse environment. The experimental results in Fig. 8 verify that the method in this paper can effectively collect the CO₂ concentration data of greenhouse environment by using wireless sensor network. At the same time, the collected CO₂ concentration data is in good agreement with the actual CO₂ concentration data, indicating that the method in this paper has high accuracy in collecting CO₂ concentration data.

The relative errors between the temperature data, humidity data, light intensity data and CO₂ concentration data collected by the method in this paper and the actual data are counted. The statistical results are shown in Table II.

TABLE II. COMPARISON OF RELATIVE ERRORS OF ENVIRONMENTAL MONITORING

Monitoring points	Temperature/%	Humidity/%	Light intensity/%	CO ₂ concentration/%
1	0.25	0.34	0.29	0.74
2	0.34	0.47	0.43	0.56
3	0.28	0.29	0.28	0.42
4	0.13	0.36	0.16	0.61
5	0.25	0.48	0.34	0.53
6	0.34	0.35	0.28	0.48
7	0.29	0.48	0.17	0.34
8	0.34	0.29	0.26	0.52
9	0.19	0.35	0.23	0.64
10	0.52	0.41	0.45	0.51

From the experimental results in Table II, it can be seen that the method in this paper uses wireless sensor network to

collect greenhouse environment data, and the relative error between the collected data and the actual data is less than 1%.

The experimental results show that the method can achieve effective monitoring of the greenhouse environment with high monitoring accuracy. According to the collected greenhouse environment data of each monitoring point, the greenhouse environment can meet the growth needs of crops. Through experimental verification, the research method can receive and display environmental data such as temperature and humidity, light intensity, and CO₂ concentration collected by sensor nodes in real time, and can view the real-time operation status of each node. During the test period, the sensors operated stably and all functions worked normally, and played an important role in the daily management of the greenhouse environment, achieving the expected results.

IV. DISCUSSION

Existing Research: wireless sensor networks have brought a revolution in information sensing due to their low power consumption, low cost, distributed and self-organizing features. Wireless sensor network consists of a large number of inexpensive miniature sensor nodes deployed in the monitoring area, which is a multi-hop self-organized network formed by wireless communication. ZigBee is a local area network protocol based on IEEE802.15.4 standard, which has the features of low cost, simplicity, short distance, automatic networking of nodes, low power consumption and low data transmission rate, and can be applied to various applications by embedded devices in automatic control field. Currently, many scholars have applied wireless sensors in greenhouse environmental monitoring. Benahmed K et al. proposed an algorithm based on wireless sensor network technology for monitoring microclimate in greenhouses and developed a linear equation model for optimizing plant production and material costs [21]. Given that subsurface soil sensing uses several types of sensors and devices that can help to monitor soil fertility in real time, Ghosh D et al. investigated the existing subsurface sensing technologies used to monitor soil fertility in agriculture using underground IoT[22]. Abbasikesbi R et al. proposed a wireless sensor network based on the proposed algorithm to improve tomato crops in greenhouses. The developed sensor nodes have low power consumption and low cost to monitor parameters such as temperature, humidity, CO, CO₂ and light intensity[23]. In all of the above studies, wireless sensors were used to monitor the greenhouse environment, but the accuracy of greenhouse environment monitoring was low because the sensors set up did not meet the needs of greenhouse environment monitoring.

Research results of this paper: Results of this study: Based on the previous research, this paper proposes an embedded greenhouse environment monitoring method based on ZigBee wireless sensor network. The ZigBee-based wireless sensor network has the features of large node size, small size, low cost and ad hoc network, which can not only realize the rapid automatic networking of sensor nodes, but also has the ability to collect, transmit, store and process various greenhouse environmental data in real time. The ZigBee-based wireless sensor network has the advantages of low cost, low power consumption, no wiring, flexible networking and friendly human-machine interface, which makes a useful exploration for the application of wireless sensor network and embedded technology in the field of greenhouse management. This

research collects greenhouse environment information through temperature sensors, humidity sensors and other sensors, and transmits the collected information to remote monitoring center through ZigBee wireless sensor network, which is convenient for greenhouse managers to remotely monitor greenhouse environment in real time and provide a good environment for crop growth.

Research limitations: Limitations of this research: Although the embedded greenhouse environment monitoring method based on ZigBee wireless sensor network used in this research can overcome some defects of traditional greenhouses in structure and performance and help to establish large-scale intelligent greenhouse clusters, there are still some shortcomings. In the actual greenhouse environment monitoring, the monitoring error is difficult to be completely eliminated because of the influence of many factors. Besides, the interaction between different influencing factors should be considered, and in addition to the monitoring of individual factors, joint analysis should be conducted in subsequent studies.

Future work: The Future of Work: Today's Internet applications are penetrating into the embedded space. 5G technology is enabling the rapid spread of smartphones. Due to the rapid development of embedded technology, web servers can run on single-chip microcomputers with high-capacity flash memory. Embedded technology will develop rapidly as various electrical devices become intelligent and Internet-enabled. With the application of these intelligent technologies in the field of environmental monitoring, the level of environmental monitoring will be greatly improved. Today, with the development of embedded intelligent technology and "5G technology", the greenhouse monitoring based on wireless sensor and network technology network has a better technical design basis than the traditional greenhouse monitoring method. The future direction of sensor technology research will be supported by 5G technology to get more development.

V. CONCLUSION

Through greenhouse environment monitoring, the indoor environment can be automatically monitored to provide suitable greenhouse environment for crops according to the requirements of different crops, thus meeting the needs of scientific research and production and accumulating rich data for intelligent agriculture experts to develop new technologies. The embedded greenhouse environment monitoring method based on wireless sensor network overcomes some defects of traditional greenhouses in structure and performance, and also has some significance for establishing large-scale intelligent greenhouse clusters. Through this research method, the parameters of temperature, humidity and light intensity in different areas of the greenhouse are obtained in real time, so that the crops can achieve a suitable growth environment and provide a convenient, efficient, adaptable, simple and practical monitoring scheme for greenhouse managers. The experiments show that the method is effective in monitoring temperature, humidity and other parameters and has high applicability.

ACKNOWLEDGMENT

The research is supported by: Project approved by Inner Mongolia Education Department: Research on discipline and specialty Integration construction of local universities under the background of “Double First-class” construction No. NJSY22136.

REFERENCES

- [1] J. Wang, M. Chen, J. Zhou, and P. Li, “Data communication mechanism for greenhouse environmental monitoring and control: an agent-based iota system”, *Information Processing in Agriculture*, vol. 7, no. 3, pp. 12, 2020.
- [2] Y. Mekonnen, S. Namuduri, L. Burton, A. Sarwat, and S. Bhansali, “Review-machine learning techniques in wireless sensor network-based precision agriculture”, *Journal of The Electrochemical Society*, vol. 167, no. 3, pp. 037522, 2020.
- [3] J. He, J. Lee, T. Song, H. Li, and K. Wang, “Delay-tolerant indoor optical wireless communication systems based on attention-augmented recurrent neural network”, *Journal of Lightwave Technology*, pp. 1-7, 2020.
- [4] C. Zhao, B. Gao, L. Wang, W. Huang, and S. Cui, “Spatial patterns of net greenhouse gas balance and intensity in Chinese orchard system”, *Science of The Total Environment*, vol. 779, no. 6, pp. 146250, 2021.
- [5] B. Hua, Z. Li, W. Gao, H. Feng, and G. Liu, “Soil amendment in plastic greenhouse using modified biochar: soil bacterial diversity responses and microbial biomass carbon and nitrogen”, *Biotechnology Letters*, 43(FEB.1PT.A), pp. 1-12, 2021.
- [6] M. L. Gu, and M. Li, “Optimization Design of Wireless Energy Transmission System Based on Improved Transmission Coil”, *Computer Simulation*, vol. 37, no. 1, pp. 284-289, 2020.
- [7] R. Anzum, and J. Naeem, “Leveraging lorawan technology for smart agricultural monitoring of malaysian palm oil plantation”, *IOP Conference Series: Earth and Environmental Science*, vol. 756, no. 1, pp. 012052, 2021.
- [8] L. Cheng, M. Xue, Y. Wang, Y. Wang, & Y. Bi, “A robust tracking algorithm based on modified generalized probability data association for wireless sensor network”, *IEEE Transactions on Industrial Electronics*, vol. 111, no. 2, pp. 1-7, 2021.
- [9] E. B. Priyanka, T. K. Devi, P. Sakthivel, and A. S. Sagayaraj, “Gate diffusion input (GDI) codes involved viterbi decoders in wireless sensor network for enhancing qos service”, *Analog Integrated Circuits and Signal Processing*, vol. 111, no. 2, pp. 287-298, 2022.
- [10] K. Ravindra, T. Singh, and S. Mor, “Covid-19 pandemic and sudden rise in crop residue burning in india: issues and prospects for sustainable crop residue management”, *Environmental Science and Pollution Research*, vol. 29, no. 2, pp. 3155-3161, 2021.
- [11] P. F. Han, N. Zeng, B. Yao, W. J. Zhou, L. Q. Chen, & Q. Shao, “Preface to special topic on atmospheric greenhouse gas measurement and application in China”, *Advances in Atmospheric Sciences*, vol. 37, no. 6, pp. 3-4, 2020.
- [12] N. Sarma, P. M. Tuohy, & S. Djurovic, “Stator electrical fault detection in dffigs using wide-band analysis of the embedded signals from the controllers”, *IEEE Transactions on Energy Conversion*, pp. 1-6, 2020
- [13] T. Pisanu, S. Garau, P. Ortu, L. Schirru, and C. Macciò, “Prototype of a low-cost electronic platform for real time greenhouse environmental monitoring: an agriculture 4.0 perspective”, *Electronics*, vol. 9, no. 5, pp. 726, 2020.
- [14] F. A. Khan, A. A. Ibrahim, & A. M. Zeki, “Environmental monitoring and disease detection of plants in smart greenhouse using internet of things”, *Journal of Physics Communications*, vol. 4, no. 5, pp. 055008, 2020.
- [15] D. Liu, J. Cui, J. Zhang, C. Y. Yang, and L. Hanzo, “Deep reinforcement learning aided routing in aeronautical ad hoc networks”, *IEEE Transactions on Vehicular Technology*, PP 1-8. 2021.
- [16] X. Sun, and S. Cao, “A routing and wavelength assignment algorithm based on two types of leo constellations in optical satellite networks”, *Journal of Lightwave Technology*, pp. 1-8, 2020.
- [17] M. G. Chen, R. Zheng, Y. Fu, J. Qi, and W. Yao, “An analog control strategy with multiplier-less power calculation circuit for flyback micro-inverter”, *IEEE Transactions on Power Electronics*, pp. 1-7, 2021.
- [18] Y. Zhao, Z. R. Zhang, S. C. Yan, & R. J. Tong, “High-sensitivity temperature sensor based on reflective solc-like filter with cascaded polarization maintaining fibers”, *IEEE Transactions on Instrumentation and Measurement*, vol. 9, no. 9, pp. 1-7, 2021.
- [19] Q. Shang, C. Cheng, J. Wang, K. Luo, & X. Yang, “Net global warming potential, greenhouse gas intensity and carbon footprint as affected by different tillage systems from Chinese double-cropping paddy fields”, *Soil and Tillage Research*, vol. 288, no. 5, pp. 104947, 2021
- [20] H. H. Lee, S. U. Kim, H. R. Han, D. Y. Hur, & C. O. Hong, “Mitigation of global warming potential and greenhouse gas intensity in arable soil with green manure as source of nitrogen”, *Environmental Pollution*, vol. 288, no. 2, pp. 117724, 2021.
- [21] Benahmed K, Touhami A, Parra L, et al. An intelligent monitoring of greenhouse using wireless sensor networks. *SMART STRUCTURES AND SYSTEMS*, vol. 26, no. 1, pp. 117-134, 2020.
- [22] Ghosh D, Anand A, Gautam S S, et al. Soil Fertility Monitoring With Internet of Underground Things: A Survey. *IEEE Micro*, vol. 42, no. 1, pp. 8-16, 2022.
- [23] Abbasikesbi R, Nikfarjam A, Nemati M. Developed wireless sensor network to supervise the essential parameters in greenhouses for internet of things applications. *IET Circuits Devices & Systems*, vol. 8, no. 14, pp. 1258-1264, 2020.