

Development of an Educational Robot for Exploring the Internet of Things

Zhumaniyaz Mamatnabiyev¹, Christos Chronis², Iraklis Varlamis³, Meirambek Zhaparov⁴

Department of Computer Sciences, SDU University, Kaskelen, Kazakhstan¹

ORCID: 0000-0003-2157-2836

Department of Informatics and Telematics, Harokopio University of Athens, Athens, Greece^{2,3}

²ORCID: 0000-0002-2768-7119

³ORCID: 0000-0002-0876-8167

ICT Faculty, Paragon International University, Phnom Penh, Cambodia⁴

ORCID: 0000-0002-2286-792X

Abstract—Educational robots, when integrated into STEM (Science, Technology, Engineering, and Mathematics) education across a range of age groups, serve to enhance learning experiences by facilitating hands-on activities. These robots are particularly instrumental in the realm of Internet of Things (IoT) education, guiding learners from basic to advanced applications. This paper introduces the IoTXplorBot, an open-source and open-design educational robot, developed to foster the learning of IoT concepts in a cost-effective manner. The robot is equipped with a variety of low-cost sensors and actuators and features an interchangeable microcontroller that is compatible with other development boards from the Arduino Nano family. This compatibility allows for diverse programming languages and varied purposes. The robot's printed circuit board is designed to be user-friendly, even for those with no engineering skills. The proposed board includes additional pins and a breadboard on the robot's chassis, enabling the extension of the robot with other hardware components. The use of the Arduino board allows learners to leverage all capabilities from Arduino, such as the Arduino IoT cloud, dashboard, online compiler, and project hub. These resources aid in the development of new projects and in finding solutions to encountered problems. The paper concludes with a discussion on the future development of this robot, underscoring its potential for ongoing adaptation and improvement.

Keywords—Educational robots; Internet of Things; IoT Education; Arduino for Education; IoT Educational Kit

I. INTRODUCTION

Recent advancements in technology have significantly transformed educational processes within classroom settings. Notable examples of these educational technologies include augmented reality [1], educational robotics [2], and large language models [3] recently, all of which have garnered considerable interest among students. However, the integration of these technologies necessitates additional efforts, particularly in the development of requisite learning materials.

The Internet of Things (IoT) is a technological paradigm that facilitates the interconnection of embedded devices via a network. These IoT devices are designed to collect data from their environment, which is subsequently stored for further analysis. The primary components utilized in the IoT development process include sensors, actuators, and controllers, in addition to network and storage elements. These components are employed by learners to gain practical experience in developing IoT applications.

There are several solutions at the hands of learners and educators for supporting IoT education and practice. For example, simulation applications, educational kits, and a few educational robots are ideal paradigms of material and platforms for learning IoT in practice and for solving a variety of everyday issues.

Educational robots are used as an interactive teaching tool that supports the development of problem-solving skills and improves practical expertise in the curricular fields [4]. They are also used to introduce students to Robotics and Programming interactively from a very early age [5].

In the context of STEM (Science, Technology, Engineering, Mathematics) education, educational robots have been widely applied to enhance instructional and learning quality [6]. They offer immersive, practical learning opportunities where students gain problem-solving experience and learn to apply knowledge in real-world contexts [7]. The interdisciplinary nature of robotics in STEM prepares students for technology-centric careers.

Educational robots are used in different ways across various age groups. For instance, in the case of infant and primary education, educational robotics provides students with everything they need to easily build and program a robot capable of performing various tasks [5]. In middle and high schools, robotics clubs often compete at local STEM competitions, where teams of students are tasked with designing and building a robot to take on opponents in a series of challenges [8].

Educational robots are not only confined to primary or secondary education but are also increasingly being incorporated into higher education. The Internet of Things fundamentally relies on the engineering and programming skills fostered by STEM education. Consequently, educational robots can be effectively utilized in IoT education. This integration allows students to design and program their own robots using IoT technologies, thereby providing a hands-on, immersive learning experience. This practical approach facilitates a deeper understanding of how IoT devices collect and exchange data, enhancing students' technical skills and preparing them for the future digital world. Furthermore, the incorporation of educational robots into IoT education can stimulate innovation and creativity, encouraging students to develop novel solutions and applications for real-world problems. Thus, the use of

educational robots extends beyond traditional STEM education, demonstrating their versatility and adaptability in various educational contexts.

While there is a growing interest among hardware manufacturers, simulation software companies, and researchers in developing solutions for Internet of Things (IoT) education, a significant challenge persists. The majority of these solutions are proprietary in nature, which inherently restricts their flexibility and expandability. This limitation poses a substantial barrier to the dynamic and evolving needs of educational contexts. Consequently, there is a pressing need for open, adaptable, and scalable solutions that can effectively support IoT education and foster innovation in teaching and learning practices.

As a solution to the above limitations, in this study, the Open Source Educational Robot for Exploring the Internet of Things (abbreviated as IoTXplorBot), an open-source and open-design robot that can be utilized in IoT education to explore a range of activities, from the simplest to the most complex is introduced. The unique features of the IoTXplorBot can be summarized as follows:

- The robot's design is open and can be modified according to requirements.
- The chassis of the robot is constructed from wood, cut into a rectangular box shape by a laser cutting machine, offering a cost-effective and sustainable solution. It can also be replaced with a 3D-printed chassis for customization.
- The electronic components used, such as sensors and actuators, are low-cost and can be replaced with other components as needed.
- The Arduino Nano microcontroller used in the robot can be replaced with other microcontrollers from the same family, depending on the specific activity or cost considerations.
- The robot is programmed using the Arduino IDE, and the program can be uploaded to it from any computer or laptop via a USB cable.
- The robot has the ability to communicate in wireless mode with a base computer for storing and analyzing data collected by the sensors.

This flexibility and adaptability make the IoTXplorBot a versatile tool for IoT education. Its robot-like shape makes it more user-friendly than a sensor kit and expands the educational capabilities in richer scenarios.

The remainder of this paper is organized as follows: Section II provides an overview of the main solutions available for IoT education and highlights the pros and cons of each approach. Section III discusses the development details of the IoTXplorBot. The robot pilot and indicative activities related to IoT course are discussed in Section IV. Section V presents discussions and limitations of the robot. Finally, Section VI concludes the paper by offering our recommendations and outlining the next steps for utilizing the robot in other related course activities.

II. RELATED WORK

A variety of desktop simulation applications and hardware kits are available for educational purposes and for prototyping IoT devices. Numerous simulation tools can be accessed online. For example, the Cisco Networking Academy offers the Packet Tracer¹ simulation tool for emulating IoT devices and networking. Similarly, Autodesk Tinkercad² provides a simulation tool for constructing circuits and prototyping devices. However, these simulation tools offer limited hands-on learning experiences. To address this limitation, commonly used hardware components (i.e. sensors) are often assembled into a single unit, referred to as a kit, which is then used for learning and prototyping purposes. Companies such as Adafruit³ and Arduino⁴ offer various types of kits equipped with different hardware components and controllers. These kits provide learners with the opportunity to construct real-world solutions and facilitate learning through practical application.

Educational robots, which are based on robotics and electronic components, serve to enhance the learning process by actively engaging students in classroom activities [9]. By participating in these activities, students can contribute to the development process of the robot for various applications. These robots provide a unique opportunity for learners to gain in-depth knowledge on a specific topic. A wide range of commercial educational robots are available on the market, catering to different age groups, from kindergarten to university level. Many of these robots are specifically designed to facilitate STEM education, thereby fostering tangible and constructive thinking among learners. In higher education, educational robots are utilized in various courses, providing learners with hands-on experiences [10], [11]. For instance, educational robots have been used for teaching Artificial Intelligence [12], data acquisition [13], or even for supporting robotics courses [14]. The learning outcomes of using educational robots in the classroom include problem-solving skills, self-efficacy, computational thinking, creativity, motivation, and collaboration [15]. However, for learning IoT in higher education, more sophisticated robots equipped with various sensors and actuators are required. Additionally, wireless communication technologies are necessary for transmitting data over the network to a remote storage facility that can handle the huge amount of collected data. Currently, there are only a limited number of robots available for this purpose and most of them use a proprietary design and code. Another drawback is their high cost, which may pose a barrier to accessibility.

Accordingly, open-source educational robots are also available under research [16]. The question arises: Are they sufficiently effective in enhancing IoT learning? Let's examine a few examples. Hydra [17] is an Arduino-based educational robot equipped with pre-wired connections to sensors and actuators, eliminating the need for additional hardware components. However, this robot does not incorporate wireless communication capabilities. EUROPA II [13] is equipped with various sensors and a Raspberry Pi microprocessor, allowing for direct programming. FOSSBot [18] bears similarities to EUROPA II but features various programming interfaces that

¹<https://www.netacad.com/courses/packet-tracer>

²<https://www.tinkercad.com/>

³<https://www.adafruit.com/category/878>

⁴<https://store.arduino.cc/collections/kits>

can be utilized by users with varying coding skills. DuckieBot [19] is designed for higher education and is equipped with a camera and a Raspberry Pi board. The ability to program directly on the board and write code in various programming languages are advantages of using Raspberry Pi. However, it is more expensive compared to other boards. Furthermore, when it is replaced with other types of boards, additional wiring is required. In Table I, a comprehensive summary of prevalent educational robots and hardware kits that are applicable for IoT learning within the context of higher education is provided. This summary includes a comparative analysis of their respective hardware components and associated costs. The primary findings derived from the utilization of these educational tools are also presented.

The educational robots and kits, reviewed in Table I, are designed for a variety of tasks. Robots in [21], [13], [22], [19], [18] are based on microprocessors such as Raspberry

Pi, which allows them to run program code directly on the processor without the need for an external computer. In contrast, robots in [20], [17] are programmed by a computer, with the code then uploaded onto the robot's microcontroller. Using a microprocessor enables the robot to be connected remotely for running software. However, microcontrollers are less vulnerable to security attacks than microprocessors as they require direct contact for uploading programming code. The benefit of using educational robots over hardware kits is that learners can plan to develop their projects on a single system, upgrading their projects over time.

While the aforementioned solutions offer a range of capabilities, their relatively high costs can pose a significant barrier, particularly when procuring multiple units for classroom use. Among the options, Hydra [17] stands out as the most cost-effective, yet it lacks the provision for robot extensions, which limits its utility for experienced users. Therefore, there is a

TABLE I. WIDESPREAD EDUCATIONAL ROBOTS AND KITS IN HIGHER EDUCATION: HARDWARE COMPONENTS AND COST ARE COMPARED

Robot/Kit	Controller/CPU	Sensors	Actuators	Cost (EUR)	Main Findings
Epuck 2 [20]	STM32F4 ARM Cortex M4	IR proximity, accelerometer, gyroscope, microphone, camera, Time of flight distance	Stepper motors, LEDs, Loud-seaker	550	A powerful robot designed for engineering education. The robot can be adapted for various exercises.
Robobo [21]	Smartphone + PIC32	Camera, accelerometer, gyroscope, GPS, magnetometer, IR proximity, light sensor	DC gear motor, LEDs	450	The robot interacts with a smartphone for performing actions. The software of the robot is implemented in the smartphone.
EUROPA II [13]	Raspberry Pi	Ultrasonic distance, IR proximity, optical encoder, camera, LIDAR	DC gear motor, robotic arm, LEDs	300	Robot Operating Systems (ROS) based educational robot with a robotic arm for performing actions. Sensors used make the robot more powerful in data collection.
Turtlebot 3 [22]	Raspberry Pi + OpenCR	Camera, LIDAR, accelerometer, gyroscope, magnetometer	MYNAMIXEL AX gear motor + driver	586	A mobile robot developed for higher education as a target audience. The robot is experienced in teaching embedded systems.
Duckiebot [19]	Raspberry Pi 2	Fish-eye camera	DC gear motor	150	An autonomous vehicle-based robot used in autonomy education and research. The robot is used and driven in a platform named Duckietown.
Hydra [17]	Arduino Mega	Ultrasonic distance, potentiometer, buttons	RGB LED, LEDs, seven segment display	35	Electronic components of the robot are designed in printed circuit boards that require no circuit creation. The robot software is based on Petri Nets modeling.
FOSSBot [18]	Raspberry Pi	Ultrasonic distance, IR proximity, gyroscope, accelerometer, camera, optical encoder, noise, gas, motion, temperature, humidity, photoresistor, IR reciever	DC gear motor, servo motor, LCD screen	100	The robot contains various sensors and actuators that enable many activities. Suitable for learning different course activities.
Arduino Explore IoT Kit ⁵	Arduino MKR WiFi 1010	Buttons, temperature, humidity, pressure, gas, ambient light, gesture, accelerometer, RGB color, PIR, moisture level	RGB LED, buzzer	125	A kit that enables to develop various projects for environment monitoring. The sensors are attached to the device which accesses no circuit creation.
SparkFun Inventor's Kit ⁶	SparkFun RedBoard Qwiic	Ultrasonic distance, temperature, photoresistor, buttons	Servo motor, DC gear motor, LCD, piezo speaker,	100	A kit that enable robotic car development. The kit includes a breadboard and microcontroller holder which all robotic components are attached.
Arduino IoT Bundle ⁷	Arduino Nano RP2040 Connect	Potentiometer, photoresistor, button, temperature, tilt	alphanumeric LCD, LEDs, bright white, DC motor, servo motor, piezo	75	A kit that enables to explore IoT projects using common sensors and actuator.

pressing need for a solution that is not only cost-effective but also expandable and open-source. Such a solution would cater to a wider range of user expertise and offer greater flexibility for adaptation and expansion, thereby enhancing its applicability in diverse educational contexts.

III. THE PROPOSED OPEN SOLUTION

A. Overview of the Robot

The IoTXplorBot (educational roBot for eXploring IoT), an open-source hardware and open-design educational robot, is built around the Arduino Nano microcontroller. Its primary objective is to augment the learning process for the Internet of Things. The robot is outfitted with two motor wheels and a motor driver to regulate the motors. Additionally, it is equipped with a variety of sensors and actuators, further enhancing its functionality and adaptability in IoT education. The full view of the robot is illustrated in Fig. 1.

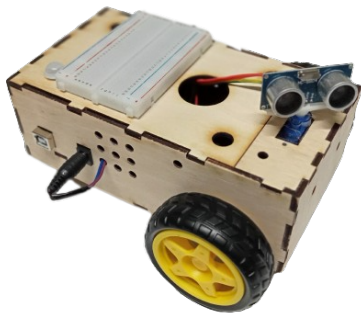

Fig. 1. Full view of the robot.

The robot proposes an open hardware and software solution that can be built by the students themselves. It provides an opportunity for hands-on experience with electronics and engineering principles. The IoTXplorBot shares similarities with the FOSSBot [18] and Hydra [17], but modifications have been made to the chassis and the controller to better adapt it for IoT learning. The previous iteration of this robot was detailed in a conference paper [23], where the Arduino UNO microcontroller board was utilised. A limitation of the previous version was the absence of wireless communication capabilities in the Arduino UNO board. In this updated version, changes to the hardware components, including the motor driver and the Inertial Measurement Unit (IMU) sensor were made. These enhancements aim to optimize the robot's functionality for IoT education.

B. IoTXplorBot Hardware

The chassis of the robot is crafted from wood using a laser cutter, resulting in a cost-effective design. Compared to a plastic 3D-printed chassis, such as FOSSbot's the cost is a bit higher. However, using wood instead of plastic dramatically reduces the printing time, and the durability of the chassis and is according to the environmental sustainability objectives that promote the use of recyclable material. The chassis is shaped like a rectangular box. Any damaged part can be easily

reprinted and replaced. The design includes several holes for ventilation to prevent overheating of the controller or motor driver. Additional holes have been made to accommodate bolts and nuts for attaching hardware components. A separate hole has been created for routing wires, ensuring a neat and organized assembly. This thoughtful design contributes to the robot's adaptability and ease of maintenance.

The electronic components of the IoTXplorBot are carefully selected to align with its intended use. These components, which are common to other kits such as the Arduino IoT Bundle and the SparkFun Inventor's Kit, must be adaptable to both course activities and robot development. The electronic suite is not only cost-effective but also replaceable with similar components, offering flexibility. These components collectively contribute to the robot's functionality and adaptability in IoT education. A list of electronic components and their approximate cost are shown in Table II.

TABLE II. LIST OF THE ROBOT PARTS AND APPROXIMATE COST

Part	Quantity	Cost (EUR)
Arduino Nano 33 IoT	1	23
Infrared Proximity Sensor	2	1
Ultrasonic Distance Sensor HC-SR04	1	1
Infrared Receiver and Remote Control	1	2
Temperature and Humidity Sensor DHT11	1	2
DC Gear Motor (6V 1:110)	2	3
Plastic wheel with tire (65x26mm)	2	1
Universal Turning Wheel (24mm)	1	0.5
L293D Motor Driver	1	0.5
Servo Motor SG90	1	2
RGB LED	1	2
Wood Chassis	1	4
9V Battery	1	4
USB to Micro USB cable	1	2
Female-to-female Jumper Wires	1	2
Printed Circuit Board	1	5
Overall		55

The Arduino Nano 33 IoT⁸, selected as the controller for the robot, offers a unique amalgamation of features and capabilities, rendering it particularly suitable for Internet of Things (IoT) applications. Despite its compact form factor, it is powered by the Arm® Cortex®-M0 32-bit SAMD21 processor, providing substantial computational power for diverse IoT applications. The board is equipped with the u-blox NINA-W102 Wi-Fi module and the ECC608A crypto-chip, ensuring secure and reliable wireless connectivity, a critical feature for IoT applications involving data transmission over networks. Furthermore, the Arduino Nano 33 IoT is compatible with the Arduino Cloud platform, facilitating the rapid construction of IoT projects, and thereby catering to both novice and experienced users. The board also incorporates an Inertial Measurement Unit (IMU), combining an accelerometer and a gyroscope, enabling the development of motion-tracking devices. Thus, the selection of the Arduino Nano 33 IoT is jus-

⁵<https://store.arduino.cc/products/explore-iot-kit-rev2>

⁶<https://www.sparkfun.com/products/21301>

⁷<https://store.arduino.cc/products/iot-bundle>

⁸<https://store.arduino.cc/products/arduino-nano-33-iot>

tified by its compact size, robust processing capabilities, secure wireless connectivity, cloud compatibility, and integrated IMU, collectively rendering it a versatile and cost-effective solution for IoT education.

Arduino offers a diverse range of Nano boards, each with distinct characteristics, integrated sensors, and wireless communication capabilities. A key feature of these boards is their seamless interchangeability, which allows users to execute various circuits without needing to alter pins and connections. For instance, the Arduino Nano is the most economical microcontroller within the Arduino family, although it lacks built-in sensors and network capabilities. In contrast, the Arduino Nano 33 BLE Sense⁹ board is notable for its Python programming compatibility and the ability to deploy machine learning models directly on its core. This particular Nano board also includes an array of integrated sensors, eliminating the need for constructing external circuits to measure data.

In the process of constructing a circuit that integrates a microcontroller with sensors and actuators in a traditional method where a breadboard is used, novice learners lacking experience in electronics may encounter challenges. These difficulties can lead to potential damage to the hardware components, particularly when they are connected to an inappropriate voltage source or when the connections are improperly configured. To address these issues, a printed circuit board (PCB) has been designed that incorporates the microcontroller and the motor driver (Fig. 2). This design facilitates the easy connection of sensors and actuators. The utilization of this connection system ensures that all external modules can be uniquely connected to the mainboard, thereby significantly reducing the likelihood of user errors. This approach enhances the learning experience by providing a more user-friendly and error-resistant platform for circuit construction. A comparison between the traditional method and the proposed approach is depicted in Fig. 3.

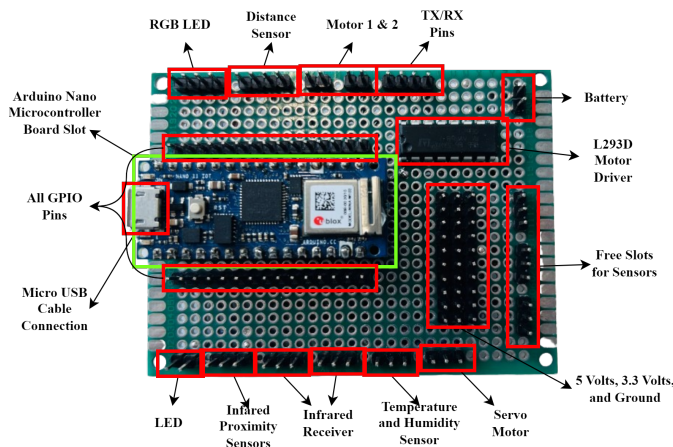

Fig. 2. Design of the proposed board.

The design of our printed circuit board (PCB) approach incorporates a slot for connecting any type of Arduino Nano board, along with other hardware components. Each slot designated for sensors and actuators includes a voltage source, ground, and a pin to the GPIO (general-purpose input/output) pins of the microcontroller board. Furthermore, the circuit

provides additional communication to all pins of the microcontroller board and power sources, which can be utilized by advanced users. The PCB also features extra slots for additional sensors and actuators, should they be required for robot extension. The designed printed circuit board must be manufactured before use.

The L293D motor driver, a key component of our design, facilitates the control of both the direction and speed of the motors, which serve as the wheels of the robot. This driver is securely affixed to the board and is connected to the microcontroller, thereby providing a ready-to-use circuit solution when the motors are integrated with the robot.

In previous iterations of the robot, the L298N motor driver was utilized. However, challenges related to its power consumption were encouraged. The L298N, while effective in many applications, is known to consume a significant amount of power. This power consumption can be problematic, particularly in applications where energy efficiency is a priority or where power resources are limited.

In contrast, the L293D motor driver offers a more power-efficient solution. It operates between 4.5V and 36V and can draw up to 1.2A from both channels. This lower power requirement makes the L293D a more suitable choice for our robot, especially considering our goal of optimizing energy efficiency. Thus, the shift to the L293D motor driver not only addresses the power consumption issue but also enhances the overall performance and efficiency of the robot.

The microcontroller of the board operates at a voltage of 3.3 Volts and is capable of handling input voltages up to 21 Volts. It possesses the capability to draw power via a USB cable connected to a computer, providing flexibility in power sourcing. However, to drive the robot and facilitate remote control, the board is connected to a 9V battery. This battery configuration eliminates the need for a battery holder, thereby simplifying the overall design. In instances where the charge of the battery exceeds its capacity, the battery is replaced with a new one. Alternatively, a rechargeable battery can be employed, offering a sustainable and cost-effective power solution. This approach ensures continuous operation of the robot while also providing flexibility in power management.

A breadboard is mounted on the top side of the robot chassis, which can be used for extending the robot by building new circuits alongside the existing robot hardware components. This comprehensive design approach ensures flexibility and scalability in robot construction and operation.

C. IoTExplorBot Software

The software for the IoTExplorBot is developed by the learners themselves, thereby facilitating a hands-on learning experience. The software is written in the Arduino Integrated Development Environment (IDE), which utilizes the C programming language, a common choice for microcontrollers. For those who are less experienced in programming, Ardublockly¹⁰ offers a block-based programming interface similar to Scratch¹¹, based on Google's Blockly¹². This provides

¹⁰<https://ardublockly.embeddedlog.com/index.html>

¹¹<https://scratch.mit.edu/>

¹²<https://developers.google.com/blockly>

⁹<https://store-usa.arduino.cc/products/nano-33-ble-sense-rev2>

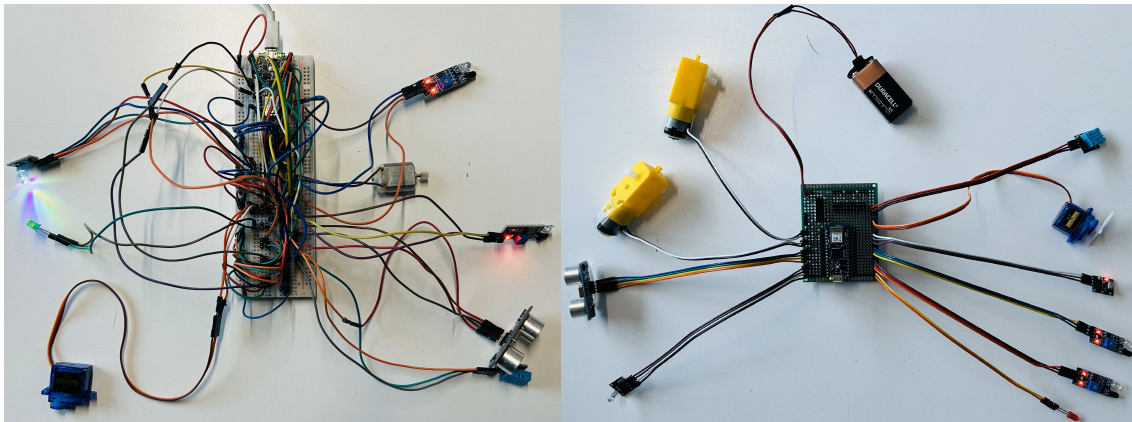

Fig. 3. Comparison between the traditional method (left) and the proposed approach (right).

a more accessible entry point for beginners. In addition, the Python programming language, which is widely used and popular, can also be employed if the Arduino Nano RP2040 Connect¹³ or Arduino Nano 33 BLE is used as the main controller in the robot. This flexibility in programming languages caters to a broad range of user expertise and preferences, further enhancing the educational value of the IoTXplorBot.

The selection of sensors and actuators for our design is not only based on their wide availability in the market at a low cost but also the availability of programming libraries and examples. The libraries and examples of programming codes for these components are readily accessible. For instance, the Arduino website hosts a forum¹⁴ and project hub¹⁵ where Arduino users can conveniently find examples and solutions to their challenges.

Another resource, SparkFun Inventor's Kit Code¹⁶, provides examples and libraries for a popular selection of sensors and actuators. These resources significantly simplify the process of programming and integrating these components into the robot, making our design approach user-friendly and cost-effective. This ensures that users, regardless of their level of experience, can successfully build and operate the robot.

The architecture of the IoTXplorBot is meticulously designed to meet all the requirements for IoT development. The programming code for the robot can be uploaded through two distinct methods: via a USB cable or wirelessly. The latter is facilitated by the built-in WiFi communication capability of the board, which enables Over-The-Air (OTA) code uploading. This feature significantly enhances the flexibility and convenience of code deployment, particularly for iterative development and testing processes. It should be noted that this wireless uploading feature is contingent upon the presence of built-in WiFi connectivity in the Arduino boards. The robot can be programmed by learners to communicate with other end devices like laptops or smartphones through wireless communication technology.

The robot is also capable of collecting environmental data and transmitting this data to the cloud for further analysis. The Arduino IoT Cloud platform¹⁷ provides to store IoT data on the cloud and display data on a dashboard. This feature enables a comprehensive exploration of IoT concepts and applications.

The inclusion of built-in Bluetooth Low Energy (BLE) communication in the microcontroller board facilitates its interaction with other devices enabled with Bluetooth communication. BLE, a power-efficient variant of the classic Bluetooth technology, is particularly suited for IoT applications where devices need to exchange small amounts of data intermittently. This feature significantly expands the robot's connectivity capabilities, enabling it to interface with a wide range of devices and sensors. Consequently, this opens up a plethora of possibilities for collaborative tasks, data collection, and even swarm robotics, thereby enhancing the educational potential of the robot. A detailed representation of communication with the IoTXplorBot is provided in Fig. 4. This communication encapsulates the versatility and adaptability of the IoTXplorBot, making it an effective tool for IoT education.

IV. IOTXPLOBOT PILOT

The primary objective of the proposed robot is to augment hands-on learning experiences within the realm of the Internet of Things (IoT). The hardware components of the IoTXplorBot have been meticulously selected to facilitate the development of a diverse array of course activities. As learners engage in these activities, they gain practical experience, progressively extending the capabilities of the robot.

The IoTXplorBot has been specifically designed to assist students and enthusiasts in navigating the multifaceted world of IoT. Equipped with an array of versatile sensors, actuators, and communication modules, the IoTXplorBot provides a plethora of opportunities for learning and experimentation. Its architecture aligns seamlessly with the three-layered architecture of IoT systems, thereby enabling learners to engage with every facet of the IoT process.

Fig. 5 provides a visual representation of how key topics and technologies of IoT align with the architecture of the

¹³<https://store.arduino.cc/products/arduino-nano-rp2040-connect>

¹⁴<https://forum.arduino.cc/>

¹⁵<https://projecthub.arduino.cc/>

¹⁶<https://learn.sparkfun.com/tutorials/sparkfun-inventors-kit-experimentguide—v41>

¹⁷<https://cloud.arduino.cc/>

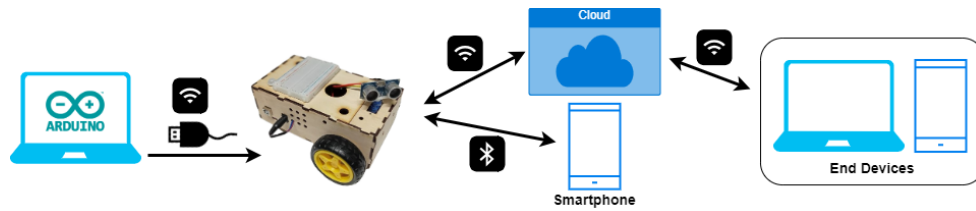

Fig. 4. Communication with the robot.

IoTXplorBot. In its operational capacity, the robot functions as an IoT device, communicating with the cloud and other applications through various communication protocols. This alignment underscores the relevance and applicability of the IoTXplorBot in the context of IoT education.

The complexity of the activities conducted using the robot progressively increases, thereby fostering the learner's growth and experience. The initial activity involves basic movements of the robot, such as moving forward/backward and turning left/right, facilitated by the robot motors and motor driver. The programming code for this activity is relatively simple, marking the learner's preliminary interaction with the robot. Subsequent activities incorporate additional sensors or actuators, thereby increasing the complexity of the tasks. For instance, the second activity could involve remote control using an infrared (IR) receiver, wherein the learner is introduced to programming using conditional statements.

As the learner progresses, they are exposed to more advanced activities, such as enabling wireless communication protocols like BLE and WiFi, and monitoring the robot through a cloud or web application. The learners are also able to leverage the capabilities offered by Arduino, such as built-in sensors, communication protocols, cloud, dashboard, and uploading programming code using Over-The-Air (OTA).

The IoTXplorBot is designed to facilitate key learning outcomes for students, encompassing areas such as engineering skills, algorithms and programming, networking and technology, and data analysis. The process of developing activities using the IoTXplorBot commences with the selection of the required sensors and actuators. Subsequently, a circuit is constructed by connecting the chosen sensors and actuators to the board. The programming code is then written on a computer and transmitted to the microcontroller board via a USB cable or OTA. The Arduino IDE provides the functionality to work with a serial monitor for reviewing the sensor data and communicating with the board. An example of an activity is illustrated in Fig. 6, which depicts a flowchart for a line-following activity. In this activity, the robot is programmed to navigate along a line using two IR proximity sensors.

During the pilot study, students from the 'Introduction to IoT' course, part of the Bachelor of Computer Sciences program, were tasked with developing different solutions using the robot. The activities included creating a line follower robot, obstacle avoidance using an ultrasonic distance sensor, controlling the robot via Bluetooth, and data collection on a server using WiFi. Despite the challenging nature of the activities, the students demonstrated commendable results in the course project. Some students even opted to use the extension of the IoTXplorBot for their projects, while others

chose their own project topics and tools. The solutions for their projects included remote monitoring using cloud technology and driving the robot via Bluetooth communication controlled by an Android application.

V. DISCUSSION

This work aims to achieve two primary objectives. The first is to develop an educational robot, the IoTXplorBot, that facilitates the learning of Internet of Things (IoT) concepts through the exploration of various hardware components. The second objective is to make this educational tool available at a low cost. Traditional methods of learning IoT typically involve the use of educational kits, which consist of a microcontroller, sensors, and actuators. These kits offer different approaches to exploring IoT concepts. The IoTXplorBot, however, provides a progressive learning experience, starting with simpler tasks and gradually leading to the development of a complex system by the end of the course activities. While there are many educational robots available on the market, they often come with high costs and a limited number of sensors and actuators. Compared to different educational kits and robots in terms of their hardware components, and costs for use in higher education, the IoTXplorBot proposes cost-effective solution and adaptability with different hardware components for the robot extension and variety of course activities.

The IoTXplorBot shares many features with the FOSSBot [18] and Hydra [17], but the proposed robot uses the Arduino Nano board, making it interchangeable with other microcontrollers from this family for different purposes. Another advantage of this robot is that its chassis is designed from wood, making it sustainable and low-cost. In addition, it can be replaced with a 3D-printed chassis or even a smartphone box from cardboard. This flexibility makes the IoTXplorBot a versatile tool for IoT education.

All hardware components such as sensors and actuators chosen and activities to be designed facilitate the learning of IoT concepts. The microcontroller selected for the robot enables the creation of circuits and the running of programs for IoT as well as for other purposes such as robot training and edge computing. In contrast, other educational robots, which are primarily based on STEM (Science, Technology, Engineering, and Mathematics) education, do not allow for the creation of circuits, an essential aspect of IoT systems and devices.

This study is primarily constrained by the hardware components and the advanced programming aspects associated with the Arduino Integrated Development Environment (IDE). To broaden the applicability of the robot in other related

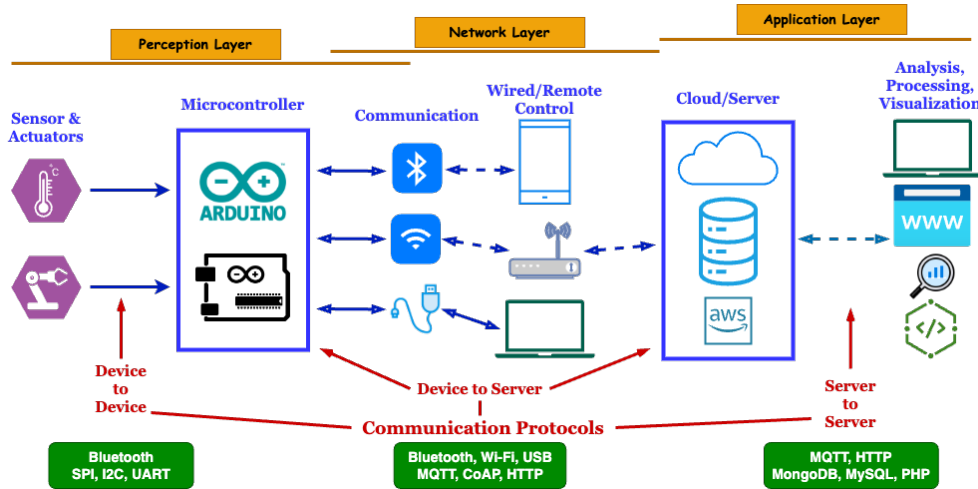

Fig. 5. Architecture of the proposed work.

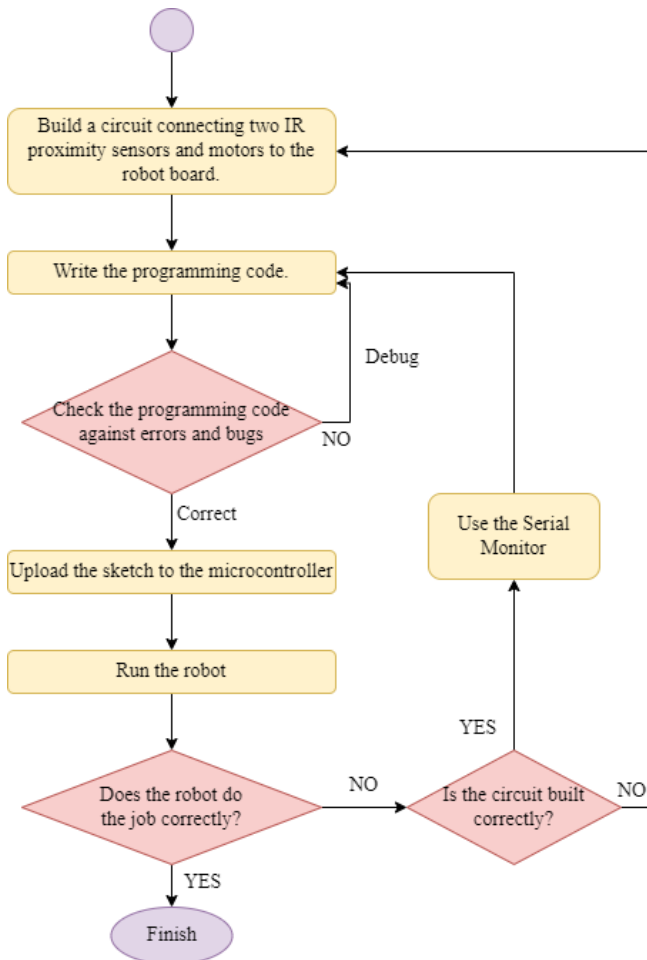

Fig. 6. Flowchart of programming the line following robot.

of an alternative microcontroller that supports the requisite programming becomes a necessity. These limitations highlight areas for future development and underscore the need for a more versatile and inclusive approach to the design and implementation of educational robots.

VI. CONCLUSION

While hardware kits composed of microcontroller boards, sensors, and actuators, along with desktop simulation applications, are commonly used in Internet of Things (IoT) education, educational robots offer a structured approach to course activities. However, various educational robots are designed to perform different tasks. The IoTXplorBot, an open-source and open-design educational robot, was developed to explore IoT concepts at a low cost. Various common sensors and actuators were utilized, enabling learners to easily find library solutions to bugs during the programming process. The microcontroller of the robot can be interchanged with other development boards from the widely used Arduino Nano family, allowing learners to choose according to their needs. During the development process, the robot was tested in the "Introduction to IoT" course as a pilot study, where students were able to use this robot for classroom activities. Most students preferred to use this robot for their course projects as a continuation of their previous tasks, despite the freedom to choose the project hardware and topic.

As part of our future work, the designed printed circuit board is planned to be fabricated for the robot to simplify tasks for students who have no experience in electronics. Additionally, the robot is planned to extend with rechargeable batteries for extended use without the need for frequent battery changes.

ACKNOWLEDGMENT

We acknowledge the use of generative AI, ChatGPT (<https://chat.openai.com/>), to refine the academic language and accuracy of our own work.

course activities, it is imperative to develop an application that caters to individuals who may not be well-versed with Arduino Programming. Furthermore, for more advanced courses such as machine learning and edge computing, the selection

REFERENCES

- [1] J. L. Belmonte, A.-J. Moreno-Guerrero, J. A. L. Núñez, and F. J. H. Lucena, "Augmented reality in education. A scientific mapping in Web of Science," *Interactive Learning Environments*, vol. 31, no. 4, pp. 1860–1874, Dec. 2020, doi: 10.1080/10494820.2020.1859546.
- [2] I. Kyriazopoulos, G. Koutromanos, A. Voudouri, and A. Galani, "Educational robotics in primary education: A systematic literature review," in *Research Anthology on Computational Thinking, Programming, and Robotics in the Classroom*, IGI Global, pp. 782-806, 2022.
- [3] T. H. Kung, M. Cheatham, A. Medenilla, C. Sillos, L. De Leon, C. Elepaño, M. Madriaga, R. Aggabao, G. Diaz-Candido, J. Maningo, et al., "Performance of ChatGPT on USMLE: Potential for AI-assisted medical education using large language models," *PLoS digital health*, vol. 2, no. 2, p. e0000198, 2023.
- [4] P. N. Mwangi, C. M. Muriithi, and P. B. Agufana, "Exploring the benefits of educational robots in STEM learning: a systematic review," *International Journal of Engineering and Advanced Technology*, vol. 11, no. 6, pp. 5-11, 2022.
- [5] U. Gerecke and B. Wagner, "The challenges and benefits of using robots in higher education," *Intelligent Automation and Soft Computing*, vol. 13, no. 1, pp. 29-43, 2007. doi: 10.1080/10798587.2007.10642948.
- [6] F. Ouyang and W. Xu, "The effects of educational robotics in STEM education: a multilevel meta-analysis," *International Journal of STEM Education*, vol. 11, no. 1, p. 7, 2024.
- [7] S. Poornima, "Importance Of Robotics In STEM Learning," *ItsMyBot*, Oct. 04, 2021. <https://itsmybot.com/importance-of-robotics-in-stem-learning/>
- [8] Ryan, "Robotics in Education: Advantages, Benefits & Importance for Kids," *iD Tech*, Apr. 06, 2021. <https://www.idtech.com/blog/educational-benefits-robotics>
- [9] D. Catlin, "29 Effective ways you can use robots in the classroom: An explanation of ERA pedagogical principle," in *Educational Robotics in the Makers Era 1*, Springer, pp. 135-148, 2017.
- [10] M. Kalaitzidou and T. P. Pachidis, "Recent Robots in STEAM Education," *Education Sciences*, vol. 13, no. 3, p. 272, 2023.
- [11] Y. Zhang, R. Luo, Y. Zhu, and Y. Yin, "Educational robots improve K-12 students' computational thinking and STEM attitudes: Systematic review," *Journal of Educational Computing Research*, vol. 59, no. 7, pp. 1450-1481, 2021.
- [12] A. Eguchi, "AI-powered educational robotics as a learning tool to promote artificial intelligence and computer science education," in *Robotics in Education: RiE 2021 12*, Springer, pp. 279-287, 2022.
- [13] G. Karalekas, S. Vologiannidis, and J. Kalomiros, "Europa: A case study for teaching sensors, data acquisition and robotics via a ROS-based educational robot," *Sensors*, vol. 20, no. 9, p. 2469, 2020.
- [14] I. Plauska and R. Damaševičius, "Educational robots for internet-of-things supported collaborative learning," in *Information and Software Technologies: 20th International Conference, ICIST 2014*, Druskininkai, Lithuania, October 9-10, 2014. Proceedings 20, pp. 346-358, 2014.
- [15] S. Evripidou, K. Georgiou, L. Doitsidis, A. A. Amanatiadis, Z. Zinonos, and S. A. Chatzichristofis, "Educational robotics: Platforms, competitions and expected learning outcomes," *IEEE Access*, vol. 8, pp. 219534-219562, 2020.
- [16] T. Sapounidis and D. Alimisis, "Educational robotics for STEM: A review of technologies and some educational considerations," in *Science and Mathematics Education for 21st Century Citizens: Challenges and Ways Forward*, pp. 167-190, Nova Science Publishers, Hauppauge, NY, USA, 2020.
- [17] G. Tsalmipouris, G. Tsinarakis, N. Gertsakis, S. A. Chatzichristofis, and L. Doitsidis, "HYDRA: Introducing a low-cost framework for STEM education using open tools," *Electronics*, vol. 10, no. 24, p. 3056, 2021.
- [18] C. Chronis and I. Varlamis, "FOSSBot: An Open Source and Open Design Educational Robot," *Electronics*, vol. 11, no. 16, p. 2606, 2022.
- [19] L. Paull, J. Tani, H. Ahn, J. Alonso-Mora, L. Carlone, M. Cap, Y. F. Chen, C. Choi, J. Dusek, Y. Fang, et al., "Duckietown: an open, inexpensive and flexible platform for autonomy education and research," in *2017 IEEE International Conference on Robotics and Automation (ICRA)*, pp. 1497-1504, 2017.
- [20] F. Mondada, M. Bonani, X. Raemy, J. Pugh, C. Cianci, A. Klapotcz, S. Magnenat, J. Zufferey, D. Floreano, and A. Martinoli, "The e-puck, a robot designed for education in engineering," in *Proceedings of the 9th Conference on Autonomous Robot Systems and Competitions*, vol. 1, no. CONF, pp. 59-65, 2009.
- [21] F. Bellas, M. Naya, G. Varela, L. Llamas, A. Prieto, J. C. Becerra, M. Bautista, A. Faina, and R. Duro, "The Robobo project: Bringing educational robotics closer to real-world applications," in *Robotics in Education: Latest Results and Developments*, pp. 226-237, 2018.
- [22] R. Amsters and P. Slaets, "Turtlebot 3 as a robotics education platform," in *Robotics in Education: Current Research and Innovations 10*, pp. 170-181, 2020.
- [23] Z. Mamatnabiyev, "Design and Implementation of an Open-Source Educational Robot for Hands-On Learning Experiences in IoT," *2023 17th International Conference on Electronics Computer and Computation (ICECCO)*, Kaskelen, Kazakhstan, pp. 1-4, 2023. doi: 10.1109/ICECCO58239.2023.10146599.