

Enhancing BLDC Motor Speed Control by Mitigating Bias with a Variation Model Filter

Abdul Rahman Abdul Majid*

Dept. of Electrical & Computer Engineering-College of Engineering, University of Sharjah, Sharjah, UAE

Abstract—Brushless DC motors (BLDC) are integral to a wide array of applications, from electric vehicles to industrial machinery, due to their superior efficiency, reliability, and performance. Effective control of BLDC motors is essential to leverage their full potential and ensure optimal operation. Traditional PID controllers often fall short in handling the nonlinear and dynamic characteristics of BLDC systems, while advanced methods like Active Disturbance Rejection Control (ADRC) introduce additional complexity and cost. This research proposes a Variation Model Filter (VMF) based control system that estimates and compensates for the total bias arising from parameter variations and internal uncertainties. This method simplifies the control process, enhances robustness, and boosts performance without requiring extensive parameter tuning or high costs. Additionally, the paper provides a comprehensive mathematical model for the speed dynamics of BLDC motors. Simulation results based on MATLAB/Simulink indicate that the VMF-based PID control system surpasses both linear ADRC and traditional PID controllers in managing speed dynamics and responding to load disturbances. This approach offers an efficient and cost-effective solution for BLDC motor speed control, with significant potential for broader application and further optimization in motor control systems.

Keywords—EV's motors; brushless direct current (BLDC) motor; active disturbances rejection control (ADRC); disturbance rejection; bias estimation; Variation Model Filter (VMF)

I. INTRODUCTION

Recent advancements in magnet technology have significantly enhanced the performance and efficiency of brushless DC (BLDC) motors, especially those using permanent magnets. These improvements have driven the growing preference for BLDC motors in various applications due to their high power density and energy efficiency [1]. Unlike their brushed counterparts, BLDC motors provide reliable and smooth operation, precise speed control, and reduced electrical noise, making them ideal for dynamic uses such as robotics and automation [2], [3]. In the electric mobility sector, BLDC motors are increasingly chosen for eco-friendly vehicles, including electric cars, scooters, and urban air transport [3]. Additionally, traditional ceiling fans that typically use split-phase induction motors (SPIMs) are now adopting BLDC motors to benefit from better energy efficiency and voltage regulation [4]. BLDC motors are poised to replace traditional induction motors in various industries, such as automotive, pumping, and rolling, by 2030 due to their superior torque, low noise, simplicity, and ease of maintenance [2]. The market for BLDC motors is expected to grow significantly, reaching an estimated value of 15.2 billion USD by 2025 [2].

Despite these advantages, BLDC motors face challenges, such as limited fault tolerance, high electromagnetic interference, acoustic noise, and torque ripple. They operate as complex, multivariable systems with load perturbations and parameter variations, leading to significant current ripple due to factors like armature reaction and phase conversion. To address these issues and enhance BLDC motor performance, researchers have focused on three main areas: motor material and structure, power electronics and drive circuit topologies, and control systems. Recent advancements in motor design include the development of the spherical brushless DC (SBLDC) motor [3], while innovations in power electronics, such as the switched-inductor Zeta active power factor correction converter (SI-ZS-APFC) [4] and phase current overlap time limiting cell (PCOTLC) [5], have significantly reduced torque ripple. Control systems remain critical for BLDC motors, as they manage the motor's operation and ensure the effectiveness of other enhancements.

Two primary control strategies are used for BLDC motor systems: scalar and vector controllers [2]. Scalar controllers include methods like Proportional-Integral-Derivative (PID), Linear Quadratic Regulator (LQR), and Active Disturbance Rejection Control (ADRC). Vector controllers encompass techniques such as Field-Oriented Control (FOC), Direct Torque Control (DTC), and intelligent methods like Particle Swarm Optimization (PSO) and Model Predictive Control (MPC). Among these, PID controllers are popular in industrial applications due to their simplicity and ease of implementation. However, PID controllers struggle with the nonlinear and dynamic nature of BLDC systems, often resulting in suboptimal performance as they are designed for linear systems and cannot handle rapid parameter changes or load disturbances effectively [1], [2], [6].

Vector control methods, including FOC and DTC, and intelligent techniques like PSO and MPC, offer improved dynamic performance and reduced torque and flux ripples. However, they also introduce higher structural and computational complexity. The literature on BLDC motor controllers lacks comprehensive surveys that compare these advanced control schemes, especially in terms of fault tolerance and reducing electromagnetic interference [2]. ADRC, particularly its linear version (LADRC), offers a balance between simplicity and performance. It estimates and compensates for total disturbances using the Extended State Observer (ESO), making it robust against both internal and external perturbations without relying on specific system models [7], [8].

ADRC, introduced by Jingqing Han in the 1990s and further refined into its linear form (LADRC) by Zhiqiang Gao [9], [10] simplifies parameter tuning and implementation for both Single-Input Single-Output (SISO) and Multi-Input Multi-Output (MIMO) systems. While LADRC is easier to implement, it may not perform as well as the nonlinear version (NLADRC) in complex, nonlinear systems. To bridge this gap, researchers have combined LADRC with artificial neural networks for nonlinear state-error feedback control (SEFC) and used intelligent techniques, like genetic algorithms, for optimal parameter tuning [8], [11]. Also, the authors in study [8] proposed to use neural-network as nonlinear SEFC and linear ESO to estimate the total disturbance, they proposed an intelligent version of ADRC (IADRC). Applications of ADRC in BLDC motor control demonstrate its capability in managing speed and current effectively [7], [12].

The study in [13] asserts that PID controllers are adequate for BLDC motor speed control, comparing them with PI and Fuzzy Logic Controllers (FLC). However, their conclusions are limited due to the absence of analysis on load disturbance response, a critical factor in real-world applications. Moreover, the study did not benchmark PID against robust controllers like Active Disturbance Rejection Control (ADRC), focusing only on traditional methods. The PID gains were also unusually high, questioning their cost-effectiveness and practical applicability. In contrast, research in [7] and [12] highlights more resilient approaches using nonlinear and linear ADRC, offering superior disturbance rejection and robustness, thus better addressing the nonlinear and dynamic challenges in BLDC motor systems.

Nevertheless, ADRC, including its linear form, faces challenges such as estimation errors in total disturbances and uncertainty in system parameters, which can impact control gains and lead to noise amplification [14]. In industrial applications, especially with available mathematical models and adequate sensors, simpler solutions like Disturbance Observer Based Control (DOBC) may suffice. Research suggests that DOBC can outperform ADRC in certain conditions due to its simpler design process [15].

This paper aims to enhance the robustness of PID control for BLDC motors by introducing a Variation Model Filter (VMF)-based approach. Unlike traditional PID controllers, which often require high gain settings and struggle with load disturbances and system uncertainties, the VMF method estimates the total bias within the system. This bias accounts for energy variations caused by parameter changes, internal uncertainties, and external disturbances. By compensating for these factors using a robust control law based on output variations from the desired response, the VMF-enhanced PID control demonstrates superior performance. Simulation results indicate that this new approach not only surpasses traditional PID controllers but also outperforms linear Active Disturbance Rejection Control (LADRC) in managing BLDC motor dynamics effectively.

The paper is structured as follows: Section II provides a detailed mathematical model of the BLDC motor. Section III introduces the VMF approach. Section IV presents simulation results, and Section V concludes the paper.

II. PROBLEM FORMULATION

To model the voltage in a three-phase BLDC motor, we start with the voltage equation for each winding. This relationship between voltage, current, and back EMF is given by:

$$\begin{bmatrix} v_a \\ v_b \\ v_c \end{bmatrix} = \begin{bmatrix} R_a & 0 & 0 \\ 0 & R_b & 0 \\ 0 & 0 & R_c \end{bmatrix} \begin{bmatrix} i_a \\ i_b \\ i_c \end{bmatrix} + \begin{bmatrix} L_a & L_{ab} & L_{ac} \\ L_{ba} & L_b & L_{bc} \\ L_{ca} & L_{cb} & L_c \end{bmatrix} \begin{bmatrix} \frac{di_a}{dt} \\ \frac{di_b}{dt} \\ \frac{di_c}{dt} \end{bmatrix} + \begin{bmatrix} e_a \\ e_b \\ e_c \end{bmatrix} \quad (1)$$

To simplify the modeling of a BLDC motor, several key assumptions are typically made. First, the stator windings are designed as full-pitch windings with a 60-degree phase belt. The air gap magnetic field is assumed to have a trapezoidal distribution with a flat top spanning 120 electrical degrees. We also disregard effects like slot impact, magnetic circuit saturation, magnetic hysteresis, eddy current loss, skin effect, and temperature influence on motor parameters.

Further simplifying, we consider the reluctance between the stator and rotor to be negligible, allowing us to set ; $L_{ab} = L_{ac} = L_{ba} = L_{bc} = L_{ca} = L_{cb} = M$. The three-phase windings are Y-connected and assumed to be symmetric, leading to $R_a = R_b = R_c = R$; $L_a = L_b = L_c = L$; and the condition $i_a + i_b + i_c = 0$; $Mi_b + Mi_c = -Mi_a$. Additionally, mechanical losses and other incidental losses of the motor are not taken into account.

Based on these assumptions, especially the symmetry in windings and negligible reluctance, the voltage equation simplifies to:

$$\begin{bmatrix} v_a \\ v_b \\ v_c \end{bmatrix} = \begin{bmatrix} R & 0 & 0 \\ 0 & R & 0 \\ 0 & 0 & R \end{bmatrix} \begin{bmatrix} i_a \\ i_b \\ i_c \end{bmatrix} + \begin{bmatrix} L - M & 0 & 0 \\ 0 & L - M & 0 \\ 0 & 0 & L - M \end{bmatrix} \begin{bmatrix} \frac{di_a}{dt} \\ \frac{di_b}{dt} \\ \frac{di_c}{dt} \end{bmatrix} + \begin{bmatrix} e_a \\ e_b \\ e_c \end{bmatrix} \quad (2)$$

To derive the current dynamics, we apply Kirchoff's law to the BLDC motor's equivalent circuit, shown in Fig. 1.

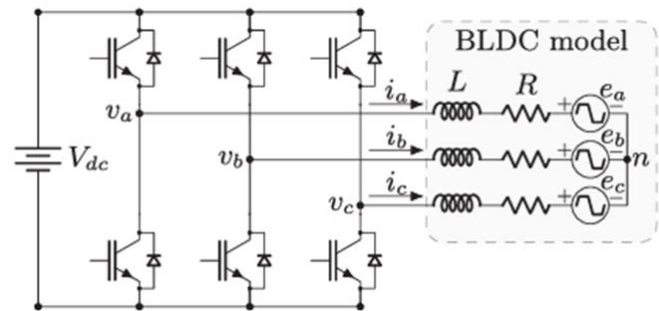

Fig. 1. BLDC motor equivalent drive circuit.

This gives us the following equation for the stator current:

$$\frac{di_s}{dt} = -\frac{R}{L-M} i_s + \frac{1}{2(L-M)} v_L - \frac{1}{2(L-M)} e_L \quad (3)$$

Here, i_s is stator current represents the stator current, while $v_L \in \{v_{ab}, v_{bc}, v_{bc}\}$, $e_L \in \{e_{ab}, e_{bc}, e_{bc}\}$ are the line-to-line voltage and back EMF, respectively, across different phases.

Given the assumptions about the stator windings and air gap magnetic field, and considering the current dynamic equation, it is feasible to control all three output currents with a single current controller. This leads us to a simplified first-order equation for the current dynamics:

$$\frac{di(t)}{dt} = f_1(i, d_e, t) + b_1 v \quad (4)$$

In this equation, $f_1(\cdot)$ encapsulates all uncertainties and disturbances in the current dynamics, with d_e representing electrical disturbances in the system given by $d_e = -\frac{1}{2(L-m)}e_L - \frac{R}{L-M}i_s$. The term b_0 is the nominal input gain for current control, equal to $\frac{1}{2(L-m)}$.

Next, we examine the electromagnetic torque, which results from the interaction between the stator winding currents and the rotor's magnetic field. This torque is defined as $T_e = \frac{e_a i_a + e_b i_b + e_c i_c}{\omega_m}$, where ω_m is the rotor speed. Assuming that all the electromagnetic power is converted into rotor kinetic energy, the power equation can be simplified to $P_e = T_e \omega_m$. At steady state, this power can be further expressed as $P_e = \frac{2E_s I_s}{\omega_m} = k_t I_s$. In this context, E_s represents the opposing electromotive force, I_s is the steady-state phase current (max amplitude), and k_t is the motor torque coefficient.

The mechanical movement of the BLDC motor is described by the following equation, which balances the generated torque T_e and the load torque T_L :

$$T_e - T_L = \frac{Jd\omega_m}{dt} + B\omega_m \quad (5)$$

where J denotes the rotary inertia, and B is the damping coefficient. By differentiating this equation and integrating the electromagnetic torque, we derive the second-order speed dynamic equation:

$$\ddot{\omega}_m = \frac{k_t}{J} \frac{di}{dt} - \frac{1}{J} (\dot{T}_L + B\dot{\omega}_m) \quad (6)$$

Rewriting it more compactly, we get:

$$\ddot{\omega}_m = f_2(\omega_m, d_m, t) + b_2 \frac{di}{dt} \quad (7)$$

Here, $f_2(\cdot)$ encompasses all uncertainties and disturbances affecting the speed dynamics, with d_m representing mechanical disturbances. The term b_2 is the nominal input gain for speed control, equal to $\frac{k_t}{J}$.

Combining the inner and outer control loops, we propose a comprehensive second-order dynamic model for the BLDC motor speed. By substituting the current dynamics into the speed dynamics, the resulting equation is:

$$\ddot{\omega}_m = f_t(f_1, f_2) + b_0 u(t) \quad (8)$$

In this final equation, $f_t(\cdot)$ aggregates all the electrical and mechanical uncertainties and disturbances, defined as $f_t = b_2 f_1 + f_2$. The nominal input gain b_0 is given by $b_0 = b_1 b_2 =$

$\frac{k_t}{2J(L-M)}$. The Eq. (4) and Eq. (8) highlight that controlling a BLDC motor involves managing a multi-loop system with an inner loop for current regulation and an outer loop for speed control, as shown in Fig. 2.

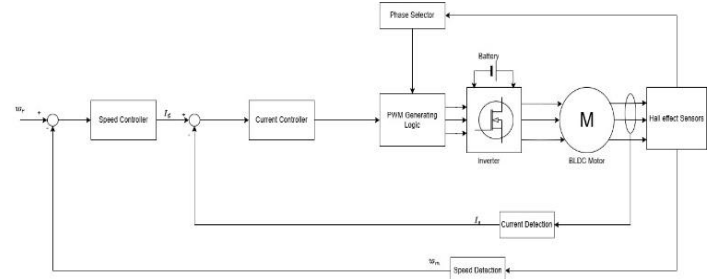

Fig. 2. BLDC motor complete system.

In controlling the speed of BLDC motors, the ADRC framework typically relies on the dynamic equation similar to Eq. (7), where an Extended State Observer (ESO) estimates and compensates for total disturbances primarily in the mechanical domain and some internal uncertainties [7], [12]. However, traditional ADRC designs often overlook electrical disturbances in the current loop, leading researchers to propose a dual-loop ADRC system [12]: one loop for managing electrical disturbances in the current and another for handling mechanical disturbances in the speed. This dual-loop approach provides a more holistic control but adds complexity. Conversely, the bias rejection strategy simplifies the process by focusing only on disturbances and uncertainties that directly impact the dominant state, termed "total bias." This technique, rather than estimating all potential disturbances, concentrates on the most significant ones, making it faster, more cost-effective, and reliable by addressing only the critical issues affecting the system's performance.

III. VARIATION MODEL FILTER (VMF)

To estimate bias accurately in a system, it's essential to develop a mathematical technique that uses a variation function for approximation. This approach involves employing a continuous approximation method based on integral transform to effectively determine and estimate the total bias. The continuous approximation can be expressed through the integral transform:

$$g(s) = \int k(s, t) f(t) dt \quad (9)$$

Here, $g(s)$ represents known information that might be influenced by noise, while $k(s, t)$ is the kernel function, and s indicates a specific domain. The unknown function $f(t)$ needs to be solved or approximated. In control applications, the system typically operates within defined constraints and spatial domains, making the first kind of Fredholm integral equation suitable:

$$\int_a^b k(s, t) f(t) dt = g(s), \quad c \leq s \leq d \quad (10)$$

In this context, $g(s)$ is given within the range $[c, d]$, which may differ from the integral's range $[a, b]$. The kernel function basis technique is often used to smooth and regularize noisy

data, minimizing errors over the approximation space. For example, if $f \in L_2[0, 1]$, the Riesz representation theorem guarantees a function $\eta_s(t) \in L_2[0, 1]$ such that:

$$\int_0^1 \eta_s(t)f(t)dt = \langle \eta_s, f \rangle, \quad s = s_1, s_2, \dots, s_n \quad (11)$$

Thus, $\eta_s(t) = k(s, t)$, indicating an appropriate basis can be deduced, and $f(t)$ can be approximated by:

$$f^*(t) = \sum_{i=1}^n a_i \eta_s(t) \quad (12)$$

To approximate the total bias in a control system, which represents the unwanted energy within the closed-loop system, leading to output variation from the desired value, we use the general continuous approximation method:

$$N(\delta f, x) = \int k(x, t)\delta f(t)dt \quad (13)$$

Here, $N(\delta f, x)$ is a nonlinear function representing the system's closed-loop output, $k(x, t)$ is the kernel function, and $\delta f(t)$ is the total bias to be estimated. Given engineering applications' spatial and constraint assumptions, the Fredholm integral of the first kind and the Riesz representation theorem provide suitable frameworks. Thus, we propose a linear method for bias estimation:

$$\delta f(t) = \sum_{i=1}^n a_i k(x_i, t) = \sum_{i=1}^k c v_i(t) = c \sum_{i=1}^k v_i(t) \quad (14)$$

This assumes $\delta f(t)$ can be approximated by a finite set of basis functions $v_i(t)$. We can rewrite this method as:

$$\delta f(t) = cV(t) \quad (15)$$

Where $V(t)$ represents the system's total variation, summing all basis functions or a suitably chosen function that provides variation information, and c relates to the regularization gain to enhance robustness. The selection of basis functions is crucial; practical applications often benefit from intuitive and knowledge-based techniques rather than purely mathematical solutions. For dynamic system input smoothing, we use a constant regularization:

$$c = \frac{c_0}{\bar{b}} \quad (16)$$

Where c_0 is a positive constant and \hat{b} is the approximated input gain. The bias estimation method using the operator form in Eq. (15) requires two types of information to find the variation function: global (general) discrepancy and smoothed (processed) discrepancy. These discrepancies reflect how the output deviates from the desired value, providing insights into the variation function. The global discrepancy $n_g(t)$ is calculated as:

$$n_g(t) = y_p(t) - y_m(t) \quad (17)$$

Where $y_p(t)$ is the system's original output and $y_m(t)$ is the reference model or observer output. The smoothed discrepancy $n_s(t)$ is found by filtering or smoothing the actual plant and model outputs:

$$n_s(t) = z_p(t) - z_m(t) \quad (18)$$

Here, $z_p(t)$ and $z_m(t)$ are the filtered outputs of the plant

and model, respectively. The variation function $V(t)$ is then approximated as:

$$V(t) = n_g(t) + n_s(t) \quad (19)$$

In summary, variation reflects output deviation due to unwanted energy (bias) in a system. In a closed-loop system, bias arises from varying parameters, uncertainties, noise, and coupling states. The variation model captures this as a function, which serves as a basis to estimate and compensate for the total bias within the system, thereby improving control performance. Fig. 3 shows the Variation Model Filter.

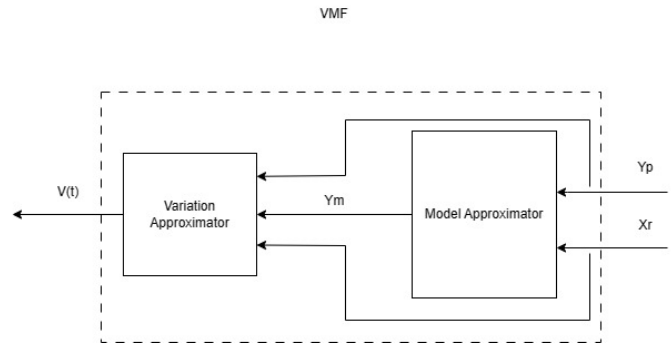

Fig. 3. Variation Model Filter (VMF).

IV. SIMULATION RESULTS AND DISCUSSION

To demonstrate the effectiveness of the proposed control technique, the system was implemented using a MATLAB library example [16], showcasing the capabilities of an ADRC (Active Disturbance Rejection Control) system. This setup allowed for a practical comparison that users could replicate and test independently. The system parameters are listed in Table I, providing the necessary context for the implementation.

TABLE I. SYSTEM PARAMETERS

Parameter	Value
Number of pole-pair	4
Stator resistance R ($m\Omega$)	1
Self-inductance L (mH)	0.2
Mutual-inductance M (mH)	0.02
Moment of inertia J ($kg.m^2$)	2
Damping coefficient B ($N.\frac{m}{rad}$)	0.1
Load when implemented (Nm)	0.1

In Fig. 4, the MATLAB/Simulink model is presented for the speed control of a Brushless DC (BLDC) motor. This comprehensive setup is designed to evaluate and compare the performance of different control strategies. The model includes a block for the BLDC motor and two main controllers: Active Disturbance Rejection Control (ADRC) and Proportional-Integral-Derivative (PID). During testing, either the ADRC or PID controller can be activated to manage the system's response.

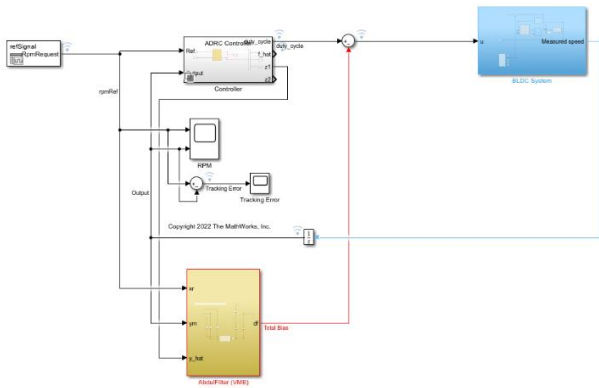

Fig. 4. Simulink Model for speed control of BLDC motor.

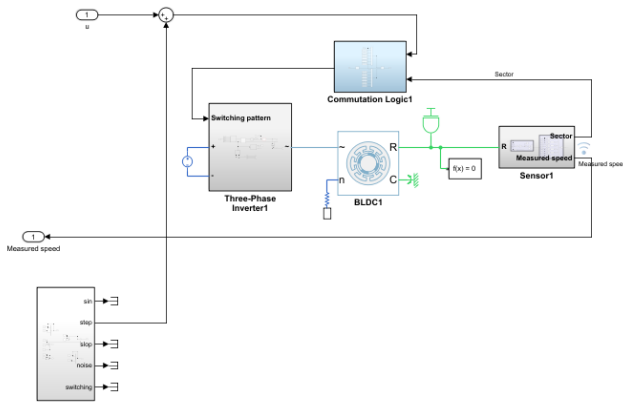

Fig. 5. BLDC motor system.

In Fig. 5, the internal structure of the BLDC motor block is delved within the model. This block encapsulates the dynamics and operational characteristics of the BLDC motor with drive circuit, commutation logic, sensor, and disturbance model, providing a detailed simulation environment for analyzing motor behavior under various control strategies.

The controller block in Fig. 4 is pivotal to the model. It includes both ADRC and PID controllers, where only one is activated at a time to control the motor. The ADRC controller uses an Extended State Observer (ESO) to estimate and counteract disturbances, thereby providing a robust control performance. The output of the ESO, denoted as \hat{y} (in model called y_hat), serves as the reference model output. This output, along with the desired speed signal x_r and the actual motor output y_m feeds into the Variation Model Filter (VMF) block.

The VMF block plays a crucial role by comparing these inputs to estimate the total bias in the system. This estimated bias is then used to enhance the performance of the control system, ensuring accurate and reliable speed control of the BLDC motor.

This setup is essential for analyzing how the different controllers handle the nonlinearities and disturbances inherent in BLDC motor systems, ultimately demonstrating the effectiveness of the VMF-based control approach.

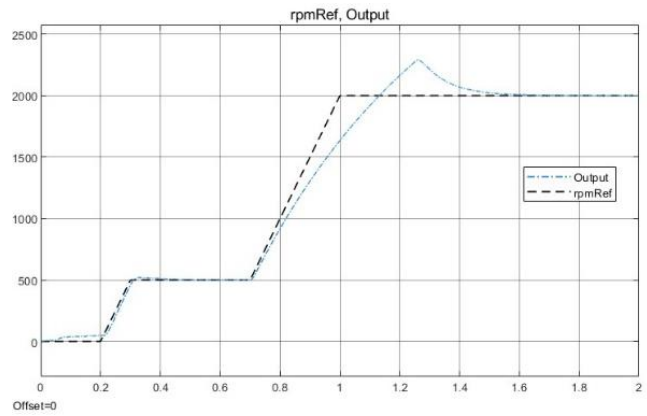

(a) PID

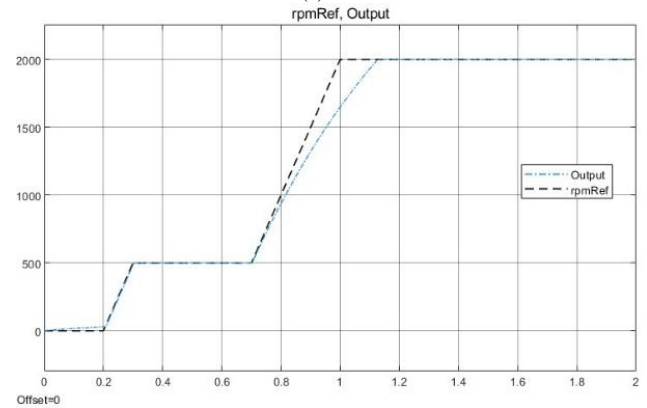

(b) ADRC

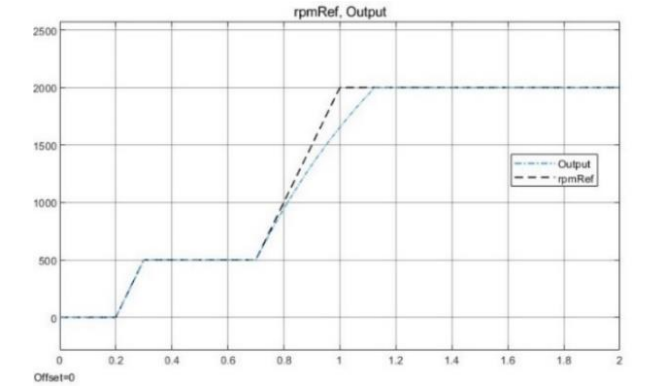

(c) VMF based PID

Fig. 6. Speed tracking performance without external load disturbances.

Fig. 6 illustrates the application of three different control strategies to manage the speed of a BLDC (Brushless DC) motor without external disturbances: conventional PID (Proportional-Integral-Derivative) control, ADRC, and PID with the Variable Mode Filter (VMF) technique. As seen in Fig. 6(a) and (b), the ADRC control system significantly outperforms the conventional PID controller. This advantage is due to ADRC's ability to estimate and reject all internal and external disturbances using an Extended State Observer (ESO), which captures these disturbances as "total disturbances". However, in Fig. 6(c), the PID controller with VMF surpasses ADRC in terms of faster response and eliminating overshoot. Fig. 7 consolidates the performance of all three controllers, providing a single display for direct comparison under the same conditions.

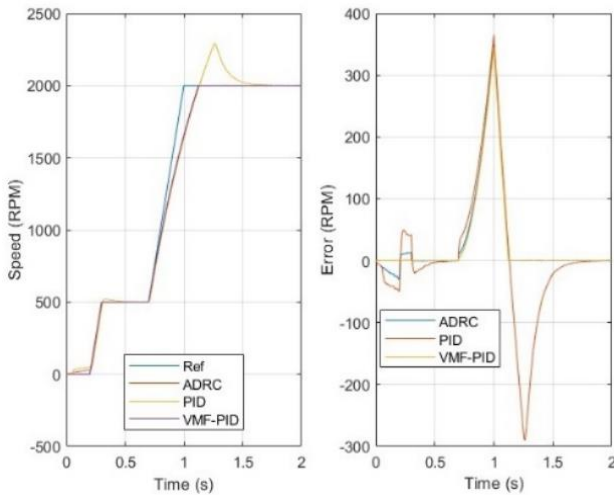

Fig. 7. Performance comparison without external disturbances.

The VMF-based approach, on the other hand, estimates the "total bias" or "discrepancy" in the system. This method simplifies the process by focusing solely on compensating for this total bias, thereby reducing complexity and cost. As illustrated in Fig. 6 and Fig. 7, the PID controller enhanced with VMF not only surpasses the conventional PID controller but also outperforms the ADRC controller in handling system discrepancies.

TABLE II. PERFORMANCE COMPARISON

Controller	Rise Time	Settling Time	Overshoot	Normalized MSE
PID	0.1778	0.5011	15.8180	0.0893
ADRC	0.1922	0.1095	0.0570	0.0381
VMF-PID	0.1901	0.1095	0.0058	0.0300

The robustness of these controllers is further evaluated under external disturbances. Table II highlights the performance differences when a load disturbance is applied, specifically observing the transient response as the motor speed changes from 500 rpm to 2000 rpm at 1 second. The comparison includes the normalized mean square error (NMSE), approximated to four decimal places, to quantify the differences among the controllers.

Fig. 8 showcases the speed tracking capabilities of the three control systems when a 0.1 Nm load is applied to the BLDC motor at 0.5 seconds, whereas Fig. 9 shows a performance comparison among them. The VMF-based PID (VM-PID) controller demonstrates superior performance, maintaining more consistent and robust control under load conditions compared to the ADRC controller and the conventional PID controller. This confirms that the VMF-enhanced PID approach is not only effective but also a more reliable solution for controlling BLDC motors, providing better handling of disturbances with less complexity.

Fig. 9 showcases the comparative performance of three different control systems—traditional PID, Active Disturbance Rejection Control (ADRC), and the proposed Variation Model

Filter-based PID (VM-PID) controller—under the impact of external disturbances on the BLDC motor. The results indicate that the VM-PID controller significantly outperforms the ADRC and traditional PID controllers when faced with external perturbations. This superior performance is attributed to the VMF's ability to estimate and reject the total bias within the system. By integrating the VMF into the PID controller, it compensates for variations, uncertainties, and disturbances, thus dramatically enhancing the robustness and effectiveness of the traditional PID approach without the complexity associated with ADRC.

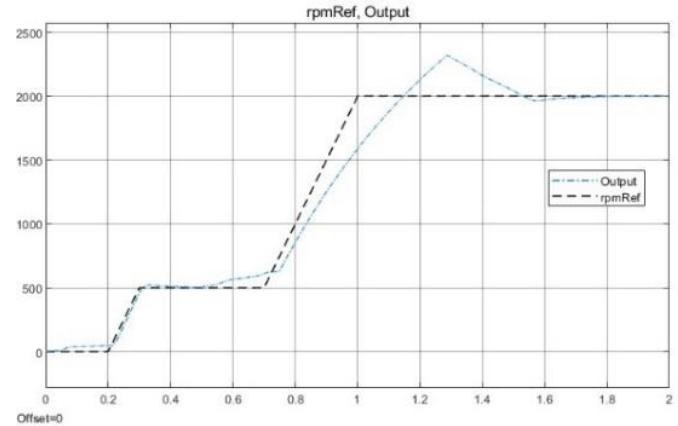

(a) PID

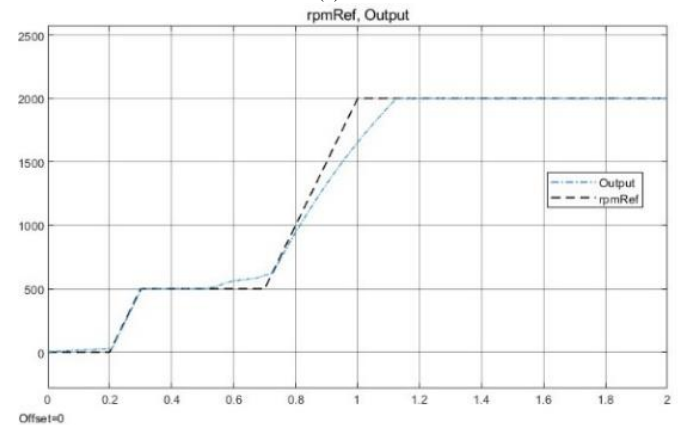

(b) ADRC

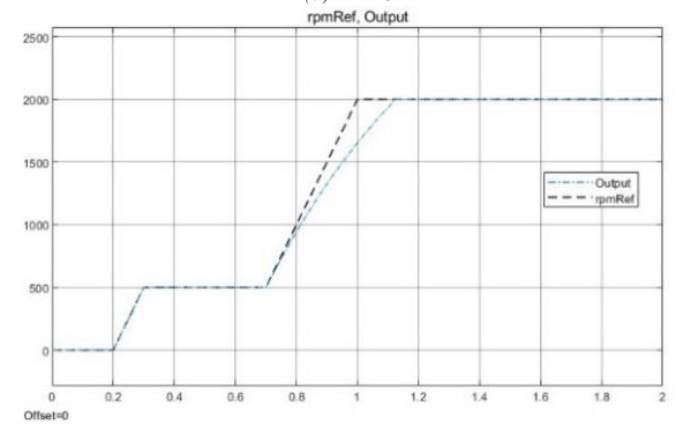

(c) VMF based PID

Fig. 8. Speed tracking performance with external load disturbances at 0.5s.

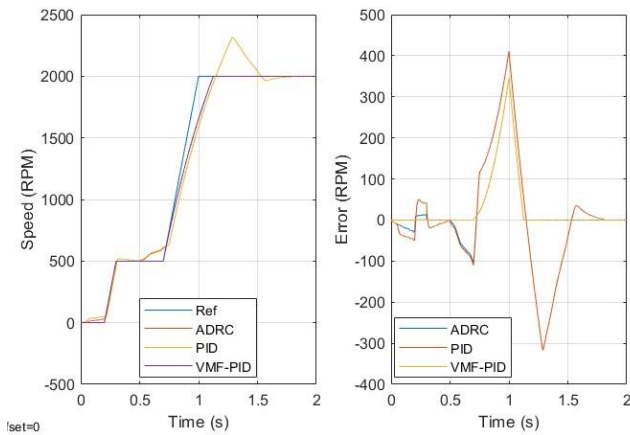

Fig. 9. Performance comparison with external disturbances.

The VM-PID controller's ability to manage and mitigate the effects of external disturbances suggests a promising enhancement over traditional PID control. The VMF allows the system to adapt dynamically to changes and disturbances by continuously estimating and adjusting for the total bias. This makes the VM-PID not only more robust but also simpler and more cost-effective compared to ADRC, which, although effective, requires complex tuning and higher implementation costs. This finding opens up an exciting avenue for further research: the integration of VMF with ADRC. Combining the bias estimation and compensation strengths of VMF with ADRC's adeptness at managing system uncertainties and disturbances could lead to a highly efficient, robust, and adaptive control system for BLDC motors and other applications.

Looking ahead, exploring a hybrid VMF-ADRC approach could provide significant improvements in motor control systems and other robotics systems. Such a combination could leverage the simplicity and robustness of the VMF-based bias compensation with ADRC's sophisticated disturbance rejection capabilities. This integration could result in a control system that not only handles complex dynamics and external disturbances more effectively but also reduces the need for extensive parameter tuning such as nonlinear ADRC cases. Future research could focus on developing and optimizing this hybrid control strategy, potentially setting a new standard for BLDC motor control in applications where both performance and robustness are critical.

It is worth mentioning, that the total bias is related to the dominant states. This means only focusing on the dominant state such as output and estimating anything that affects to those states and this kind of limitation for this technique. Thus, combining this technique with disturbances estimation techniques will dramatically improve the performance of control systems. Thus, it is suggested that in future work combining VMF with ADRC to propose a very robust control system.

In conclusion, the results and comparisons demonstrate the superiority of the VMF technique over traditional methods. The advantages of this approach include:

- 1) It is a completely model-free method, requiring no prior knowledge of the system model.
- 2) It enhances both the response and robustness of control systems.
- 3) The technique is simple to implement and does not require extensive parameter tuning.

V. CONCLUSION

In conclusion, this paper provides a comprehensive comparative study of control techniques for brushless DC (BLDC) motors, emphasizing a new method based on the Variation Model Filter (VMF). BLDC motors are increasingly popular across various applications due to their high efficiency and performance, necessitating effective control mechanisms to handle their complex dynamics. Traditional PID controllers often struggle with the nonlinear and time-varying characteristics of BLDC systems, resulting in less-than-optimal performance under varying conditions. Although advanced methods like Active Disturbance Rejection Control (ADRC) offer better disturbance management, they introduce additional complexity and cost, which can be a significant drawback in practical applications.

The VMF-based approach proposed in this study provides an innovative solution by focusing on estimating and compensating for the total bias within the system. This total bias encompasses the effects of parameter variations, internal uncertainties, and external disturbances on the dominant states, which are crucial for maintaining robust control. By integrating VMF into the PID control framework, the system can effectively handle these biases, resulting in enhanced robustness and simplified implementation compared to ADRC. Simulation results consistently show that the VMF-enhanced PID controller outperforms both traditional PID and linear ADRC controllers in managing speed dynamics and responding to load disturbances, achieving superior control performance without extensive tuning or added complexity.

This research makes significant contributions by offering a detailed mathematical model for BLDC motor speed dynamics and introducing a new technique for bias estimation. The VMF-based PID control system strikes a balance between performance and simplicity, providing a cost-effective and efficient solution for BLDC motor control. Additionally, this study lays the groundwork for future research, suggesting potential exploration into hybrid approaches that combine the robust bias estimation of VMF with the advanced disturbance rejection capabilities of ADRC. Such combinations could potentially enhance control performance and adaptability further, paving the way for broader applications and optimization of control systems in BLDC motors and beyond.

REFERENCES

- [1] K. Kroičs and A. Būmanis, "BLDC Motor Speed Control with Digital Adaptive PID-Fuzzy Controller and Reduced Harmonic Content," *Energies*, vol. 17, no. 6, p. 1311, Mar. 2024, doi: 10.3390/en17061311.
- [2] D. Mohanraj et al., "A Review of BLDC Motor: State of Art, Advanced Control Techniques, and Applications," *IEEE Access*, vol. 10, pp. 54833–54869, 2022, doi: 10.1109/ACCESS.2022.3175011.
- [3] S. Lee and H. Son, "Six Steps Commutation Torque and Dynamic Characteristics of Spherical Brushless Direct Current Motor," *IEEE*

- Trans. Ind. Electron., vol. 71, no. 5, pp. 5045–5054, May 2024, doi: 10.1109/TIE.2023.3285976.
- [4] A. Kumar and B. Singh, “High-Performance Brushless Direct-Current Motor Drive for Ceiling Fan,” *IEEE Trans. Ind. Electron.*, vol. 71, no. 7, pp. 6819–6828, Jul. 2024, doi: 10.1109/TIE.2023.3294649.
- [5] U. Soni and R. Tripathi, BLDC motor specific PCOTLC converter with active current wave shaping for torque ripple minimization. 2018, p. 6. doi: 10.1109/ETECHNXT.2018.8385331.
- [6] S. Ok, Z. Xu, and D.-H. Lee, “A Sensorless Speed Control of High-Speed BLDC Motor Using Variable Slope SMO,” *IEEE Trans. Ind. Appl.*, vol. 60, no. 2, pp. 3221–3228, Mar. 2024, doi: 10.1109/TIA.2023.3348081.
- [7] P. Zhang, Z. Shi, B. Yu, and H. Qi, “Research on the Control Method of a Brushless DC Motor Based on Second-Order Active Disturbance Rejection Control,” *Machines*, vol. 12, no. 4, p. 244, Apr. 2024, doi: 10.3390/machines12040244.
- [8] A. R. A. Majid, R. Fareh, and M. Bettayeb, “Intelligent Active Disturbance Rejection Control for Quadrotor System,” in 2022 International Conference on Electrical and Computing Technologies and Applications (ICECTA), Ras Al Khaimah, United Arab Emirates: IEEE, Nov. 2022, pp. 190–195. doi: 10.1109/ICECTA57148.2022.9990070.
- [9] J. Han, “From PID to active disturbance rejection control,” *IEEE Trans. Ind. Electron.*, vol. 56, no. 3, pp. 900–906, 2009.
- [10] Z. Gao, “Active disturbance rejection control: From an enduring idea to an emerging technology,” in 2015 10th International Workshop on Robot Motion and Control (RoMoCo), Poznan, Poland: IEEE, Jul. 2015, pp. 269–282. doi: 10.1109/RoMoCo.2015.7219747.
- [11] Z. Yan and Y. Zhou, “Application to Optimal Control of Brushless DC Motor with ADRC Based on Genetic Algorithm,” in 2020 IEEE International Conference on Advances in Electrical Engineering and Computer Applications (AEECA), Dalian, China: IEEE, Aug. 2020, pp. 1032–1035. doi: 10.1109/AEECA49918.2020.9213554.
- [12] P. Kumar, A. R. Beig, D. V. Bhaskar, K. A. Jaafari, U. R. Muduli, and R. K. Behera, “An Enhanced Linear Active Disturbance Rejection Controller for High Performance PMBLDCM Drive Considering Iron Loss,” *IEEE Trans. Power Electron.*, vol. 36, no. 12, pp. 14087–14097, Dec. 2021, doi: 10.1109/TPEL.2021.3088418.
- [13] M. Mahmud, S. M., A. H., and A. Nurashikin, “Control BLDC Motor Speed using PID Controller,” *Int. J. Adv. Comput. Sci. Appl.*, vol. 11, no. 3, 2020, doi: 10.14569/IJACSA.2020.0110359.
- [14] R. Fareh, M. Al-Shabi, M. Bettayeb, and J. Ghommam, “Robust Active Disturbance Rejection Control For Flexible Link Manipulator,” *Robotica*, vol. 38, no. 1, pp. 118–135, Jan. 2020, doi: 10.1017/S026357471900050X.
- [15] H. V. Nguyen, T. Vo-Duy, and M. C. Ta, “Comparative Study of Disturbance Observer-Based Control and Active Disturbance Rejection Control in Brushless DC Motor Drives,” in 2019 IEEE Vehicle Power and Propulsion Conference (VPPC), Hanoi, Vietnam: IEEE, Oct. 2019, pp. 1–6. doi: 10.1109/VPPC46532.2019.8952367.
- [16] “Design Active Disturbance Rejection Control for BLDC Speed Control Using PWM - MATLAB & Simulink.” Accessed: Jun. 02, 2024. [Online]. Available: <https://www.mathworks.com/help/slcontrol/ug/design-adrc-for-bldc-motor.html>.